



GRINNELL PUBLIC WORKS OR GROUNDS COMMITTEE REGULAR
SESSION MEETING
MONDAY, FEBRUARY 16, 2026, AT 4:45 PM
IN THE COUNCIL CHAMBERS ON THE 2ND FLOOR OF CITY HALL
AND VIA ZOOM
[HTTPS://ZOOM.US/J/91282310980?PWD=KSYYVXXSAGYDT3UFRCB
V1YNNIKNJWA.1](https://zoom.us/j/91282310980?pwd=KSYYVXXSAGYDT3UFRCBV1YNNIKNJWA.1)

MEETING ID: 912 8231 0980
PASSCODE: 591606

TENTATIVE AGENDA

A. Roll Call:

B. Perfecting and Approval of Agenda:

C. Committee Business:

1. Consider approval of a right-of-way request from Aureon for the Emera project at 1020 Main Street.
2. Consider approval of a Hauled Waste Agreement with Oskaloosa Food Products.
3. Discuss 4th Avenue Street Reconstruction Project from State Street to East Street.
4. Consider approval of a resolution setting the public hearing on proposed plans, specifications, and form of contract and estimate of cost and directing publication of notice to bidders for the construction of the 16th Avenue Paving Project. (See Resolution No. 2026-18)

D. Inquiries: Public Comment

Visitors may address the Council/Board at this time; however, comments will be limited to 2 minutes. As per Iowa's Open Meetings Law, Council/Board can only listen during public comments and cannot take any action on items that are not posted on the agenda. Council may take issues under advisement and if needed refer them to a department head, Mayor's committee, or add them to a future agenda.

E. Adjourn:

Any person with a disability who requires a modification or accommodation in order to participate in the meeting, or any person with limited English proficiency (LEP) who requires language assistance to communicate with the City Council during the meeting, should contact the City Clerk, (641) 236-2600 or adevig@grinnelliowa.gov, no fewer than two business days prior to the meeting to enable the City of Grinnell to make reasonable arrangements to assure accessibility or language assistance for the meeting.

City of Grinnell

PUBLIC RIGHT-OF-WAY COMMUNICATIONS SYSTEM LICENSE APPLICATION ORDINANCE NO. 1060

1. Applicant: Aureon (INS) 7760 Office Plaza Dr. South
Name Address
West Des Moines, IA 50266 515-830-0445
City, State Zip Telephone

2. Contact Person: Matt Weiser 7760 Office Plaza Dr. South
Name Address
West Des Moines, IA 50266 515-830-0497
City, State Zip Telephone

3. Application requires an engineering site plan for the proposed system that is to be placed within the City Right-of-way. Check off each of these items as they are included on the site plan:

- Plans drawn to scale.
- Street names.
- Right-of-way widths.
- Pavement widths.
- Sidewalk location and width including sidewalk ramps.
- Obstacles or improvements that are in or near the work area.
An example of such are: existing trees, fence, drainage structures,
Water stop-boxes, ditches, and utility vaults.
- Horizontal and vertical location and physical size of the proposed utility.
- Proposed construction work method such as “open cut” or “bore”.
- A drawing and explanation of concrete or asphalt restoration.
- Information regarding sod work and tree replacement.
- Location of other existing utilities within the work area.
- Typical detail sections where special attention is required for some restoration work.
- Excavation soil replacement and compaction requirements. Aggregate replacement under street surfaces, soil backfill outside of 5’ from edge of street surface.
- Detailed time schedule.
- Address of adjacent properties.
- Legal description of communication system location.

4. List any other items of concern particular to this project:
5. **Administrative Fee:** An Administrative fee of \$50.00 shall be due and payable to the City Engineer at the time of filing of the initial license application and at the time of filing of each proposed amendment to the license. (Attach copy of receipt)
Receipt No. __.
6. **Use Fee: (Serving no additional customers)** If the licensed serves no customers other than itself, then in addition to the Administrative Fee, the licensee shall pay a use fee to the City Engineer at the time of filing of the initial license application. The amount of the use fee shall be the greater of the following two (2) amounts: \$100.00 or \$1.00 per lineal foot of route traversed by the communication line within any public right-of-way in a C-2 zone and \$0.50 per lineal foot in any other part of the city. At the time of filing of each proposed amendment to the license involving an increase in the length of route traversed within public right-of-way, the licensee shall pay to the City Engineer an additional fee computed at the rate of \$1.00 per lineal foot of additional route of traversed within any public right-of-way.

(Serving additional customers) If the licensed system serves customers other than the licensee itself, then, in addition to the administrative fee, the licensee shall pay an annual use fee to the City Engineer. The annual use fee shall be based on a license year ending on March 31 of each year, and the use fee for each license year shall be due and payable at the end of such year on March 31, or if the license has terminated during such year, on the date of termination. The amount of the annual use fee shall be the greater of the following two (2) amounts: \$100.00, or three percent of the gross revenues derived by the licensee from the sale or exchange of services in connection with the operation of the licensee's communications system within the public right-of-way during the license year. Each annual use fee payment shall be accompanied by a report from the licensee in a form approved by the City Manager and the city legal department showing the basis for the computation of the fee and such other relevant data as may be required by the City Manager and the city legal department. Each such report shall contain a notarized verification by the chief financial officer of the licensee, and upon request by the city, such reports shall be verified by a certified public accountant at the expense of the licensee.

Office Use Only

Fees:	Administrative Fee:		<u>\$50.00</u>
	Use Fee:		
	(No Additional Customers) Greater of \$100.00 or:		
	Linear Feet Within C-2: <u>770</u>	x \$1.00	<u>770.00</u>
	Linear Feet Outside C-2: _____	x \$0.50	<u> </u>
		Total:	<u>\$ 820.00</u>

**(Additional Customers) Greater of \$100.00 or 3% Gross Revenues from Services.
Paid annually.**

Date of Acceptance 2/2/2026

Date of Approval _____

Staff TA

AUREON NETWORK SERVICES
GRINNELL, POWESHIEK CO., IOWA

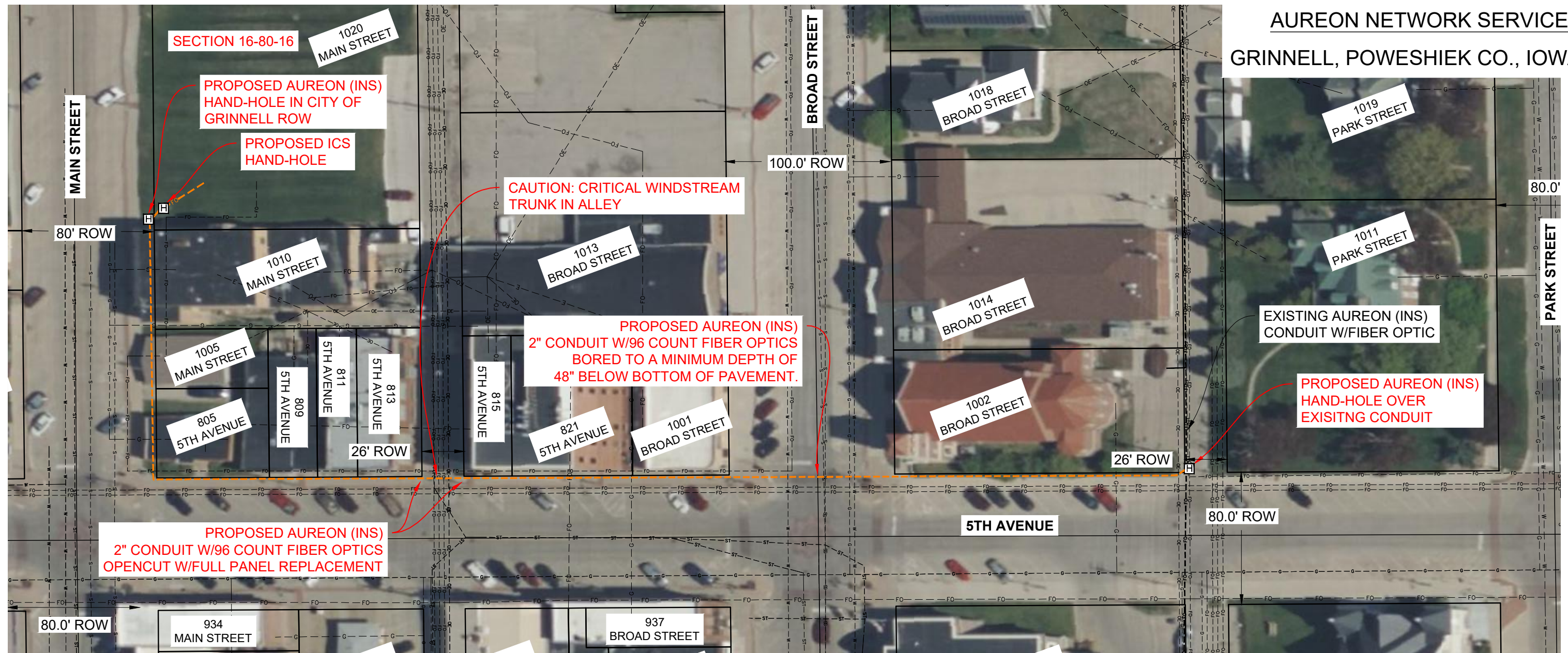

NOTES

1. ALL ROADS, PAVED DRIVEWAYS AND SIDEWALKS WILL BE BORED.
2. DISTANCES SHOWN ARE APPROXIMATE ONLY. CONTRACTOR WILL FIELD VERIFY CONDITIONS AND MATERIALS NEEDED PRIOR TO CONSTRUCTION.
3. ALL TRAFFIC CONTROL SHALL BE IN ACCORDANCE WITH THE LATEST EDITION OF THE MANUAL ON UNIFORM TRAFFIC CONTROL DEVICES (MUTCD). CONTRACTOR TO OBTAIN ALL APPLICABLE PERMITS INCLUDING BUT NOT LIMITED TO CLOSURE PERMITS. ALL PERMITS SHALL BE OBTAINED PRIOR TO CONSTRUCTION.
4. THERE ARE NO LANE CLOSURES OR TRAFFIC DISRUPTIONS ANTICIPATED WITH THIS PROJECT.
5. IOWA ONE CALL DESIGN TICKET 552000316 WAS SUBMITTED FOR UTILITY MAPS FOR THIS PROJECT.

UTILITY WARNING

ANY UTILITIES SHOWN HAVE BEEN LOCATED FROM MAPS AND RECORDS OBTAINED BY THIS SURVEYOR. THE SURVEYOR MAKES NO GUARANTEE THAT THE UTILITIES SHOWN COMPRISE ALL THE UTILITIES IN THE AREA, EITHER IN SERVICE OR ABANDONED. THE SURVEYOR FURTHER DOES NOT WARRANT THAT THE UTILITIES SHOWN ARE IN THE EXACT LOCATION SHOWN. A REQUEST WAS MADE TO IOWA ONE CALL FOR THE UTILITIES PROVIDERS TO LOCATE THEIR UTILITIES IN THE FIELD.

PROPOSED:

- 784'-2" HDPE ORANGE CONDUIT W/96CT FIBER OPTIC
- 2= HAND-HOLES



LEGEND

TELEPHONE PEDESTAL		SIGN	
WATER VALVE		POWER POLE	
FIRE HYDRANT		TELEVISION PEDESTAL	
TELEPHONE LINE		SANITARY SEWER MANHOLE	
CABLE TELEVISION LINE		STORM SEWER MANHOLE	
FIBER OPTICS LINE		ROUND STORM SEWER INTAKE	
WATERMAIN		STORM SEWER INTAKE	
STORM SEWER		UNDERGROUND CONDUIT	
SANITARY SEWER		HANDHOLE	
GAS LINE		FIBER OPTIC VAULT	
ELECTRIC LINE		FIBER OPTIC MANHOLE	
OVERHEAD ELECTRIC LINE			

PROJCT #2509.691

ESTIMATED PLOWING	ESTIMATED BORES	BACKHOE WORK	TRENCHING	MISC.	NOTES

AUREON

PROJECT NO. _____
GRINNELL, IOWA Sheet 1 of 2

#	REVISION	DATE	NAME	SCALE:
1		9/19/25		
2		1/23/26		

SCALE:

DATE: 9/17/2025

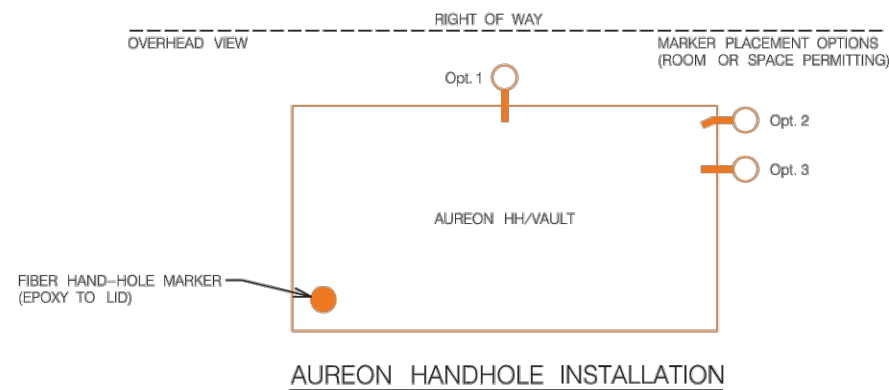
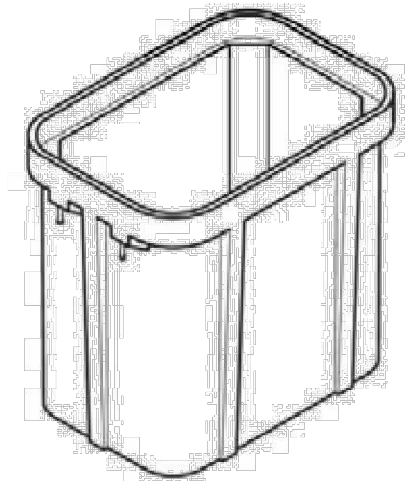
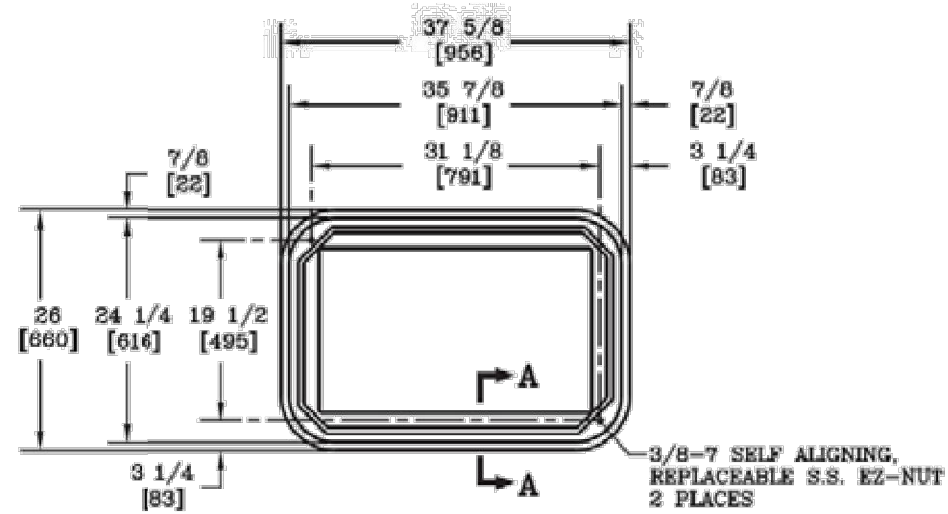
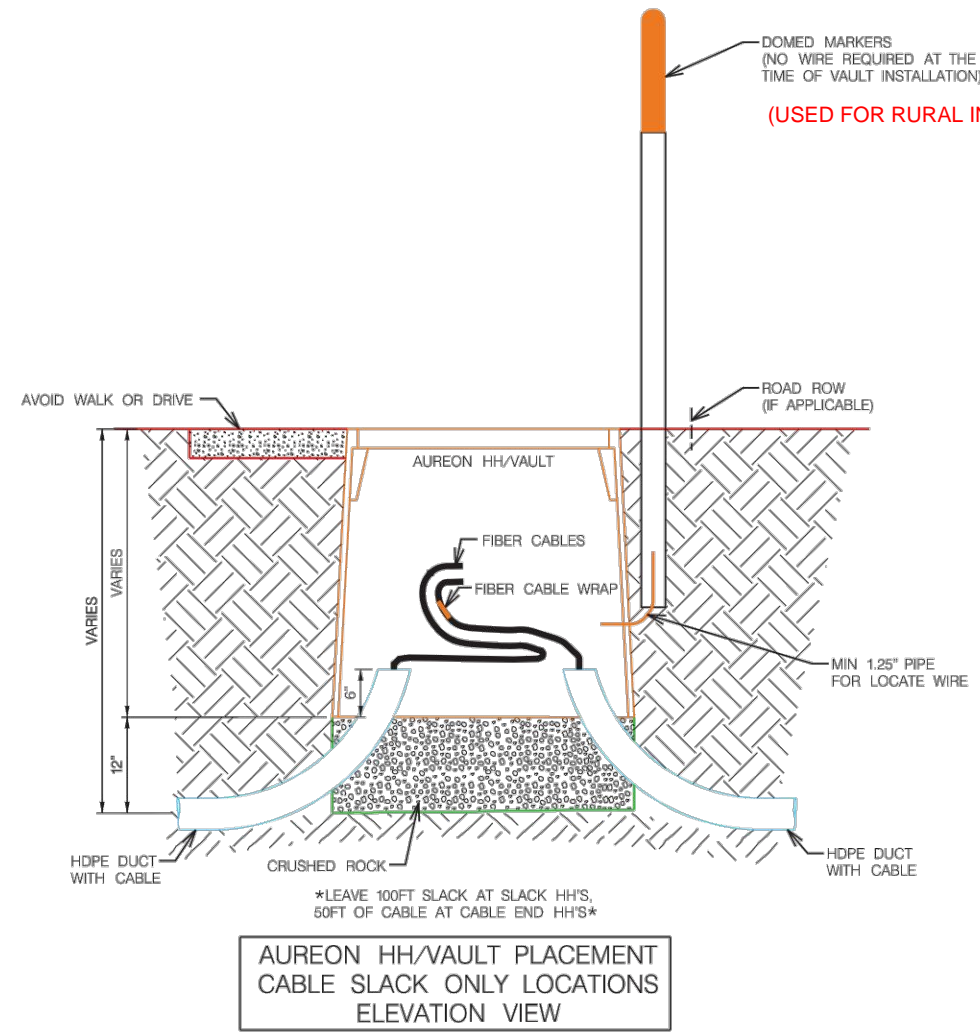



ESTIMATED PLOWING	ESTIMATED BORES	BACKHOE WORK	TRENCHING	MISC.	NOTES

AUREONTM
PROJECT NO. _____
Sheet

#	REVISION	DATE	NAME	SCALE:

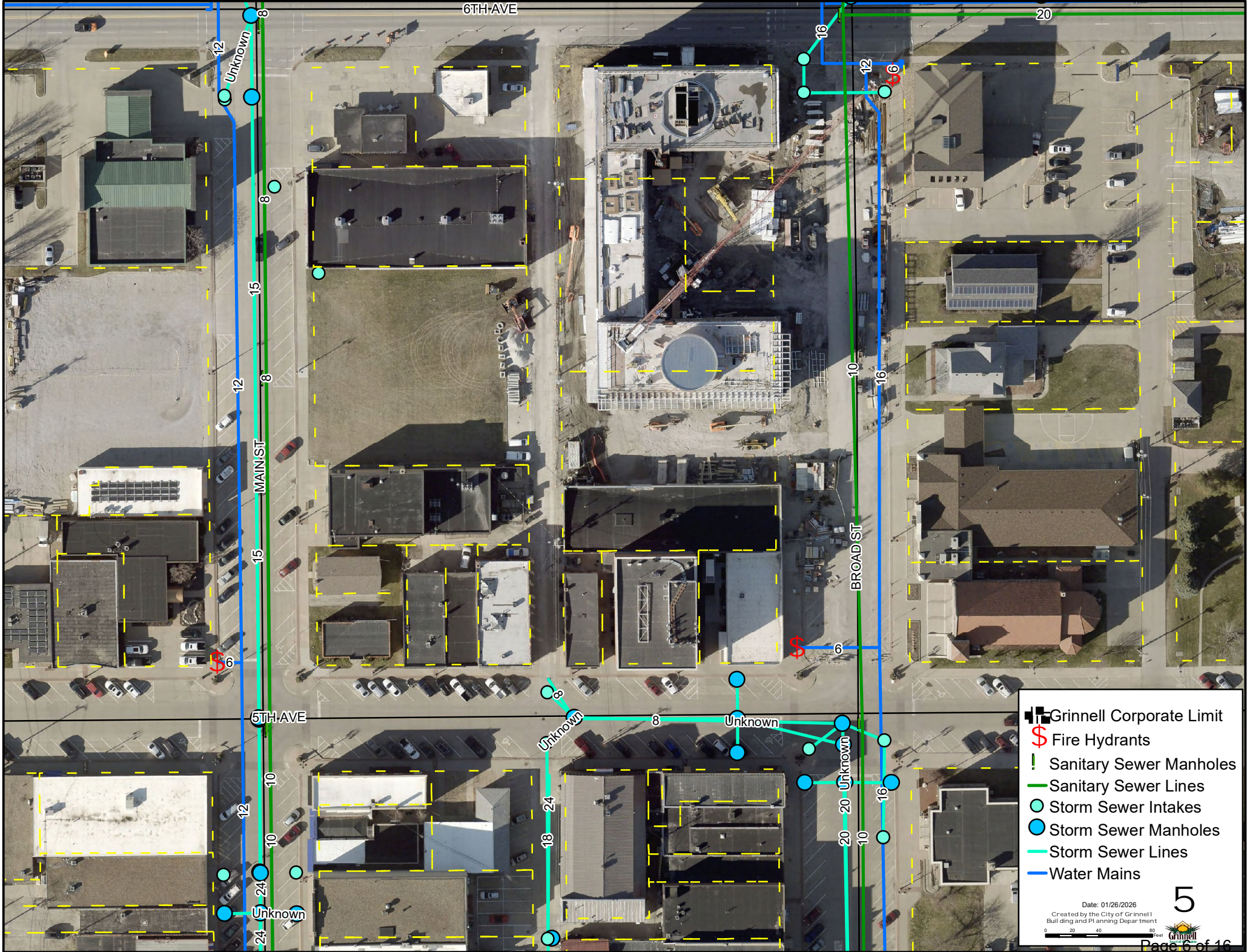
DATE: _____



-  Grinnell Corporate Limit
-  Fire Hydrants
-  Sanitary Sewer Manholes
-  Sanitary Sewer Lines
-  Storm Sewer Intakes
-  Storm Sewer Manholes
-  Storm Sewer Lines
-  Water Mains

Date: 01/26/2026
 Created by the City of Grinnell
 Building and Planning Department



City of Grinnell Hauled Waste Agreement with Oskaloosa Food Products

WHEREAS, the City of Grinnell operates a sanitary sewer system and wastewater treatment facility to treat and dispose of sanitary sewage in order to protect the public health, safety and welfare; and

WHEREAS, Oskaloosa Food Products has requested to bring its sanitary sewage to the Grinnell wastewater treatment facility for its treatment and disposal on a short term basis; and

WHEREAS, the City of Grinnell has agreed to accept the waste from Oskaloosa Food Products in accordance with the terms in this Agreement.

Now, therefore, the City of Grinnell (the "City") and Oskaloosa Food Products ("OFP") agree to the following:

1. This Agreement shall become effective on the date it is approved by both parties, and it shall expire on **DATE**.
2. This Agreement may be terminated by either party, by providing written notice of termination to the other party. Termination shall be effective upon receipt of the notice of termination.
3. The conditions of the City of Grinnell Code of Ordinances, including Chapter 97 – Use of Public Sewers, shall govern this agreement.
4. OFP may discharge loads only at locations designated by the City's Wastewater Superintendent. Unless otherwise approved, waste from OFP shall be discharged into the middle equalization basin, as directed by the Wastewater Superintendent.
5. OFP may discharge loads between the hours of 8:00 am and 3:00 pm on Monday through Friday, unless prior arrangements have been made. No load may be discharged without prior consent of the Wastewater Director. After-hours hauling, if prior arrangements were made, will result in overtime charges for city personnel at the rate of \$27/hour, with a one hour minimum.
6. The Wastewater Director may require the waste hauler to collect samples to ensure treatability and compliance with applicable Standards.
7. The Wastewater Superintendent reserves the right to reject the discharge of industrial hauled waste.
8. OFP shall pay a disposal fee to the City in the amount of \$18.50 per 100 gallons of waste. The disposal fee, including any overtime charges, shall be paid fully within seven days of delivery. Any payment received longer than 30 days after delivery will incur a 10% administrative charge.
9. Waste delivered by OFP shall comply with OFP's pretreatment requirements, as approved by the Iowa Department of Natural Resources ("IDNR"). If OFP discharges waste that causes the City to

Commented [KS1]: Is this for a specific term? Or do you want it to continue until terminated?

City of Grinnell Hauled Waste Agreement with Oskaloosa Food Products

exceed the limits established in the City's NPDES permit, OFP shall be invoiced for any and all fines, penalties, or charges assessed against the City.

10. Any notice required or permitted to be delivered pursuant to this Agreement shall be in writing and shall be deemed delivered: (a) upon delivery if delivered in person; (b) after three (3) business days, if deposited in the United States mail; (c) upon transmission, if sent via email. Notice shall be addressed to the following:

If to the City: Russ Behrens, Grinnell City Manager rbehrens@grinnelliowa.gov

If to OFP: **Name, address email**

11. This Agreement shall be governed by and enforced in accordance with the laws of the State of Iowa.
12. OFP shall indemnify, defend, and hold the City harmless against all claims, demands, damage, injury, loss, expense, or regulatory fines or fees ("losses") incurred by the City arising out of (i) the City's collection and delivery of OFP's sewage to the City's sewage system, unless such Losses were caused by the sole negligence of the City or its employees, agents or contractors; (ii) the negligence of OFP, or its employees, agents, or contractors; (iii) a material breach of this Agreement by OFP; or (iv) a violation of federal, state or local law, rule, regulation, or policy by OFP.
13. OFP shall maintain the following insurance for the duration of this Agreement.
- A. Comprehensive General Liability with policy limits of not less than One Million Dollars (\$1,000,000) for each occurrence and Two Million Dollars (\$2,000,000) in the aggregate for bodily injury and property damage.
- B. Automobile Liability covering owned and rented vehicles operated by OFP with policy limits of not less than One Million Dollars (\$1,000,000) combined single limit and aggregate for bodily injury and property damage.
- OFP shall provide to the City certificates of insurance evidencing compliance with the requirements in this Section.

City of Grinnell

Name: Sam Cox

Title: Mayor

Signature:

Date:

City of Grinnell Hauled Waste Agreement with Oskaloosa Food Products

Oskaloosa Food Products

Name:

Title:

Signature:

Date:

4928-1232-0399-1\10542-1000

RESOLUTION NO. 2026-18

RESOLUTION SETTING PUBLIC HEARING ON PROPOSED PLANS, SPECIFICATIONS, AND FORM OF CONTRACT AND ESTIMATE OF COST AND DIRECTING PUBLICATION OF NOTICE TO BIDDERS FOR THE CONSTRUCTION OF THE 16TH AVENUE PAVING PROJECT IN THE CITY OF GRINNELL, IOWA.

WHEREAS the proposed plans, specifications, and form of contract costs will be placed on file in the office of the City Clerk for the construction of the 16th Avenue Paving Project in the city of Grinnell, Iowa, as is fully set forth in the plans and specifications, and

WHEREAS the cost of the said improvement is in excess of the amount required to hold a public bid and a public hearing on the plans, specifications, form of contract and the estimated cost of said improvement is required by law and that notice thereof shall be given as required by law, and

NOW, THEREFORE, BE IT RESOLVED BY THE COUNCIL OF THE CITY OF GRINNELL, IOWA:

Section 1. This Council does hereby order the construction of the 16th Avenue Paving Project in the city of Grinnell, Iowa, which public improvement is fully and particularly described in the plans and specifications, to be placed on file in the office of the City Clerk of Grinnell, Iowa.

Section 2. That the method of construction shall be by contract in accordance with the plans and specifications and general stipulations for said improvement approved by the City Council.

Section 3. The City Clerk is hereby directed to publish notice of hearing on plans, specifications, and form of contract in the manner provided by law for the public improvement outlined herein and that any person interested therein may appear and make objections thereto. The Council will meet in the Council Chambers at City Hall at 520 4th Avenue Grinnell, Iowa, at 7:00 pm local time on the 2nd day of March 2026, for the purpose of hearing of said objections made and for taking final action upon the plans, specifications, and form of contract now on file.

Section 4. The City Clerk is further directed to advertise for bids in the manner provided by law for the construction of said improvements, setting forth in said notice such necessary pertinent information as will advise prospective bidders thereof together with the proposed manner of payment of the work to be constructed and that such bids be filed and received by the office of the City Clerk of Grinnell, Iowa, up to 2:00 pm, local time, on the 24th day of March 2026. The bids will be opened, read, and tabulated at that time and will be acted upon by the City Council of said City at a meeting to be held in the Council Chambers at City Hall at 520 4th Avenue Grinnell, Iowa, at 7:00 pm local time on the 6th day of April 2026.

Passed this 16th day of February 2026.

CITY OF GRINNELL, IOWA

SAM COX, MAYOR

ATTEST:

ALYSSA DEVIG, CITY CLERK/FINANCE DIRECTOR

NOTICE OF PUBLIC HEARING

NOTICE OF PUBLIC HEARING ON THE PROPOSED PLANS AND SPECIFICATIONS, PROPOSED FORM OF CONTRACT AND ESTIMATED CONSTRUCTION COST FOR THE CONSTRUCTION OF 16th AVENUE HMA PAVING IMPROVEMENTS, FOR THE CITY OF GRINNELL, IOWA.

At 7:00 P.M. on the 2nd day of March 2026, the City Council of said City will, in said Council Chambers, hold a hearing and said Council proposes to adopt plans, specifications, form of contract and estimate of cost and, at the time, date and place specified above, or at such time, date and place as then may be fixed, to act upon proposals and enter into a contract for the construction of the following improvements:

16th AVENUE HMA PAVING IMPROVEMENTS

16th Avenue HMA Paving Improvements – from the end of PCC pavement north of the Grinnell College golf course to the Union Pacific Railroad Crossing Project including all labor, materials and equipment necessary for saw-cutting, pavement reclamation and new HMA shoulder construction, drainage improvements, HMA overlay, storm sewer and intakes, fixture adjustments, driveway and sidewalk construction, restoration, and miscellaneous associated work, including cleanup.

At said hearing, the City Council will consider the plans, specifications, proposed form of contract, and estimated total cost for the project, the same now being on file in the office of the City Clerk, reference to which is made for a more detailed and complete description of the proposed improvements, and at said time and place the said Council will also receive and consider any objections to said plans, specifications, estimate of cost and form of contract made by any interested party.

This notice is given by order of the Council of the City of Grinnell, Iowa.

CITY OF GRINNELL, IOWA

Sam Cox, Mayor

ATTEST:

Alyssa Devig, City Clerk

NPH-1

288191

NOTICE TO BIDDERS

NOTICE OF TAKING BIDS FOR THE CONSTRUCTION OF THE 16th AVENUE HMA PAVING IMPROVEMENTS PROJECT FOR THE CITY OF GRINNELL, IOWA

Sealed proposals will be received by the City Clerk of the City of Grinnell, Iowa, in the Council Chambers, City Hall, 520 Fourth Avenue, Grinnell, Iowa 50112 until 2:00 P.M. on the 24th day of March 2026, for the construction of the 16th Avenue HMA Paving Improvements project, as described in the plans and specifications therefor, now on file in the office of the City Clerk. Proposals will be opened and the amount of the bids announced by the City Clerk at the time and date specified above. Plans and specifications for the project will be available on February 24, 2026, or shortly thereafter.

Also, at 7:00 P.M. on the 6th day of April 2026, the City Council of said City will, in said Council Chambers, or at such time, date and place as then may be fixed, to act upon proposals and enter into a contract for the construction of said improvements.

The location of the work to be done and the kinds and sizes of materials proposed to be used are as follows:

16th AVENUE HMA PAVING IMPROVEMENTS

16th Avenue HMA Paving Improvements – from the end of PCC pavement north of the Grinnell College golf course to the Union Pacific Railroad Crossing Project including all labor, materials and equipment necessary for saw-cutting, pavement reclamation and new HMA shoulder construction, drainage improvements, HMA overlay, storm sewer and intakes, fixture adjustments, driveway and sidewalk construction, restoration, and miscellaneous associated work, including cleanup.

All work and materials are to be in accordance with the proposed plans, specifications, form of contract and estimate of cost now on file in the office of the City Clerk of Grinnell, Iowa, and by this reference made a part thereof as though fully set out and incorporated herein.

All proposals in connection therewith shall be submitted to the City Clerk of said City on or before the time herein set for said letting. All proposals shall be made on official bidding blanks furnished by the City, and any alterations in the official form of proposal will entitle the Council, at its option, to reject the proposal involved from consideration. Each proposal shall be sealed and plainly identified.

NB-1

288191

Notice to Bidders

Each proposal shall be made out on a blank form furnished by the municipality and must be accompanied in a sealed envelope by either (1) a certified or cashier's check drawn on a solvent Iowa bank or a bank chartered under the laws of the United States or a certified share draft drawn on a credit union in Iowa or chartered under the laws of the United States, in an amount equal to five percent (5%) of the bid, or (2) a bid bond executed by a corporation authorized to contract as a surety in the State of Iowa, in the penal sum of five percent (5%) of the bid.

The bid security should be made payable to the CITY OF GRINNELL, IOWA. The bid security must not contain any conditions either in the body or as an endorsement thereon. The bid security shall be forfeited to the City as liquidated damages in the event the successful bidder fails or refuses to enter into a contract within 10 days after the award of contract and post bond satisfactory to the City insuring the faithful fulfillment of the contract and the maintenance of said work, if required, pursuant to the provisions of this notice and other contract documents. Bidders shall use the bid bond form bound in the specifications.

By virtue of statutory authority, preference will be given to products and provisions grown and coal produced within the State of Iowa, and to Iowa domestic labor, to the extent lawfully required under Iowa Statutes.

The City Council reserves the right to reject any or all bids and to waive informalities or technicalities in any bid and to accept the bid which it deems to be in the best interest of the City.

The Council reserves the right to defer acceptance of any proposal for a period not to exceed sixty (60) calendar days from the date of letting.

The successful bidder will be required to furnish a bond in an amount equal to one hundred percent (100%) of the contract price, said bond to be issued by a responsible surety approved by the City Council and shall guarantee the faithful performance of the contract and the terms and conditions therein contained and shall guarantee the prompt payment for all materials and labor and protect and save harmless the City from claims and damages of any kind caused by the operations of the Contractor, and shall guarantee the work against faulty workmanship and materials for a period of four (4) years after its completion and acceptance by the City Council.

The work will commence within ten (10) days after date set forth in written Notice to Proceed and shall be completed no later than October 1, 2026.

Liquidated damages in the amount of Five Hundred Dollars (\$500.00) per consecutive calendar day will be assessed for each day that work shall remain uncompleted after the end of the contract period, with due allowance for extensions of the contract period due to conditions beyond the control of the Contractor.

NB-2

288191

Notice to Bidders

Payment to the Contractor for said improvements will be made in cash derived from the proceeds of the issuance and sale of such bonds and/or from such cash funds of the City as may be legally used for said purposes. Any combination of the above methods of payment may be used at the discretion of the City Council.

Payment to the Contractor will be on the basis of monthly estimates equivalent to ninety-seven percent (97%) of the contract value of the work completed and payments made to material suppliers for materials ordered specifically for the project or delivered to the site during the preceding calendar month. Estimates will be prepared approximately 10 days prior to the first Monday of the following month by the Contractor, subject to the approval of the Engineer, who will certify to the City for payment. The City reviews and approves estimates on the first Monday of the month. Such monthly payments shall in no way be construed as an act of acceptance for any part of the work partially or totally completed. Upon completion of the work and its acceptance by the Council, the Contractor will be paid an amount which, together with previous payments, will equal ninety-seven percent (97%) of the contract price of the contract. Final payment of the remaining three percent (3%) will be made not less than thirty-one (31) days after completion and acceptance by resolution of the City Council of the completed contract, subject to the conditions and in accordance with the provisions of Chapter 573 of the Code of Iowa, as amended. No such partial or final payments will be due until the Contractor has certified to the City that the materials, labor and services involved in each estimate have been paid for in accordance with the requirements stated in the specifications.

The City will issue a sales tax exemption certificate applicable for all materials purchased for the project.

Plans and specifications governing the construction of the proposed improvements, and also the prior proceedings of the City Council referring to and defining said proposed improvements are hereby made a part of this notice and the proposed contract by reference and the proposed contract shall be executed in compliance therewith.

Copies of said plans and specifications will be on file in the office of the City Clerk, for examination by bidders on or about February 24, 2026. Copies may be obtained from VEENSTRA & KIMM, INC., 6775 Vista Drive, West Des Moines, Iowa 50266 at no charge.

NB-3

288191

Notice to Bidders

This notice is given by order of the Council of the City of Grinnell, Iowa.

CITY OF GRINNELL, IOWA

Sam Cox, Mayor

ATTEST:

Alyssa Devig, City Clerk

NB-4

288191