



GRINNELL PUBLIC WORKS OR GROUNDS COMMITTEE REGULAR
SESSION MEETING
MONDAY, MARCH 16, 2026, AT 4:45 PM
IN THE COUNCIL CHAMBERS ON THE 2ND FLOOR OF CITY HALL
AND VIA ZOOM
[HTTPS://ZOOM.US/J/93700208264?PWD=WDQRDWP4R4A0VJU2AFAI
8YR5WKQJYC.1](https://zoom.us/j/93700208264?pwd=WDQRDWP4R4A0VJU2AFAI8YR5WKQJYC.1)

MEETING ID: 937 0020 8264
PASSCODE: 549516

TENTATIVE AGENDA

A. Roll Call:

B. Perfecting and Approval of Agenda:

C. Committee Business:

1. Consider approval of a right-of-way request from Aureon for fiber near the hospital.
2. Consider approval of a resolution setting a public hearing on the proposed plans, specifications, and form of contract and directing publication of notice to bidders for the construction of the 2026 Seal Coat Project. (See Resolution No. 2026-26)
3. Consider approval of the Free Brush Dump Weekend April 11th and 12th and Free Curbside the week of April 13th.
4. Consider approval of a resolution accepting Change Order No. 3 in the amount of \$8,817.42 with WRH, Inc. for the Water Treatment Plant Project. (See Resolution No. 2026-27)
5. Consider approval of a resolution ordering bids, approving plan, specifications, form of contract and notice to bidders fixing amount of bid security and ordering Clerk to publish notice for a public hearing on plans, specifications, form of contract and estimate of costs for the construction of the Apron Construction Improvements Project at the Grinnell Regional Airport. (See Resolution No. 2026-28)

D. Inquiries: Public Comment

Visitors may address the Council/Board at this time; however, comments will be limited to 2 minutes. As per Iowa's Open Meetings Law, Council/Board can only listen during public comments and cannot take any action on items that are not posted on the agenda. Council may take issues under advisement and if needed refer them to a department head, Mayor's committee, or add them to a future agenda.

Any person with a disability who requires a modification or accommodation in order to participate in the meeting, or any person with limited English proficiency (LEP) who requires language assistance to communicate with the City Council during the meeting, should contact the City Clerk, (641) 236-2600 or adevig@grinnelliowa.gov, no fewer than two business days prior to the meeting to enable the City of Grinnell to make reasonable arrangements to assure accessibility or language assistance for the meeting.

1

E. Adjourn:

Any person with a disability who requires a modification or accommodation in order to participate in the meeting, or any person with limited English proficiency (LEP) who requires language assistance to communicate with the City Council during the meeting, should contact the City Clerk, (641) 236-2600 or adevig@grinnelliowa.gov, no fewer than two business days prior to the meeting to enable the City of Grinnell to make reasonable arrangements to assure accessibility or language assistance for the meeting.

4. List any other items of concern particular to this project:
5. **Administrative Fee:** An Administrative fee of \$50.00 shall be due and payable to the City Engineer at the time of filing of the initial license application and at the time of filing of each proposed amendment to the license. (Attach copy of receipt)
Receipt No. __.
6. **Use Fee: (Serving no additional customers)** If the licensed serves no customers other than itself, then in addition to the Administrative Fee, the licensee shall pay a use fee to the City Engineer at the time of filing of the initial license application. The amount of the use fee shall be the greater of the following two (2) amounts: \$100.00 or \$1.00 per lineal foot of route traversed by the communication line within any public right-of-way in a C-2 zone and \$0.50 per lineal foot in any other part of the city. At the time of filing of each proposed amendment to the license involving an increase in the length of route traversed within public right-of-way, the licensee shall pay to the City Engineer an additional fee computed at the rate of \$1.00 per lineal foot of additional route of traversed within any public right-of-way.

(Serving additional customers) If the licensed system serves customers other than the licensee itself, then, in addition to the administrative fee, the licensee shall pay an annual use fee to the City Engineer. The annual use fee shall be based on a license year ending on March 31 of each year, and the use fee for each license year shall be due and payable at the end of such year on March 31, or if the license has terminated during such year, on the date of termination. The amount of the annual use fee shall be the greater of the following two (2) amounts: \$100.00, or three percent of the gross revenues derived by the licensee from the sale or exchange of services in connection with the operation of the licensee's communications system within the public right-of-way during the license year. Each annual use fee payment shall be accompanied by a report from the licensee in a form approved by the City Manager and the city legal department showing the basis for the computation of the fee and such other relevant data as may be required by the City Manager and the city legal department. Each such report shall contain a notarized verification by the chief financial officer of the licensee, and upon request by the city, such reports shall be verified by a certified public accountant at the expense of the licensee.

Office Use Only

Fees:	Administrative Fee:		<u>\$50.00</u>
	Use Fee:		
	(No Additional Customers) Greater of \$100.00 or:		
	Linear Feet Within C-2: _____	x \$1.00	_____
	Linear Feet Outside C-2: <u>80</u>	x \$0.50	<u>40.00</u>
		Total:	<u>\$90.00</u>

**(Additional Customers) Greater of \$100.00 or 3% Gross Revenues from Services.
Paid annually.**

Date of Acceptance 1/29/2026

Date of Approval _____

Staff TA

AUREON NETWORK SERVICES
GRINNELL, IOWA



NOTES

1. ALL ROADS, PAVED DRIVEWAYS AND SIDEWALKS WILL BE BORED.
2. DISTANCES SHOWN ARE APPROXIMATE ONLY. CONTRACTOR WILL FIELD VERIFY CONDITIONS AND MATERIALS NEEDED PRIOR TO CONSTRUCTION.
3. ALL TRAFFIC CONTROL SHALL BE IN ACCORDANCE WITH THE LATEST EDITION OF THE MANUAL ON UNIFORM TRAFFIC CONTROL DEVICES (MUTCD). CONTRACTOR TO OBTAIN ALL APPLICABLE PERMITS INCLUDING BUT NOT LIMITED TO CLOSURE PERMITS. ALL PERMITS SHALL BE OBTAINED PRIOR TO CONSTRUCTION.
4. THERE ARE NO LANE CLOSURES OR TRAFFIC DISRUPTIONS ANTICIPATED WITH THIS PROJECT.
5. IOWA ONE CALL DESIGN TICKET 552000316 WAS SUBMITTED FOR UTILITY MAPS FOR THIS PROJECT.

UTILITY WARNING

ANY UTILITIES SHOWN HAVE BEEN LOCATED FROM MAPS AND RECORDS OBTAINED BY THIS SURVEYOR. THE SURVEYOR MAKES NO GUARANTEE THAT THE UTILITIES SHOWN COMPRISE ALL THE UTILITIES IN THE AREA, EITHER IN SERVICE OR ABANDONED. THE SURVEYOR FURTHER DOES NOT WARRANT THAT THE UTILITIES SHOWN ARE IN THE EXACT LOCATION SHOWN. A REQUEST WAS MADE TO IOWA ONE CALL FOR THE UTILITIES PROVIDERS TO LOCATE THEIR UTILITIES IN THE FIELD.

PROPOSED:

- 65'-2" HDPE ORANGE CONDUIT W/96CT FIBER OPTIC
- [H] 1= HAND-HOLE



LEGEND

TELEPHONE PEDESTAL	[Symbol]	SIGN	[Symbol]
WATER VALVE	[Symbol]	POWER POLE	[Symbol]
FIRE HYDRANT	[Symbol]	TELEVISION PEDESTAL	[Symbol]
TELEPHONE LINE	[Symbol]	SANITARY SEWER MANHOLE	[Symbol]
CABLE TELEVISION LINE	[Symbol]	STORM SEWER MANHOLE	[Symbol]
FIBER OPTICS LINE	[Symbol]	ROUND STORM SEWER INTAKE	[Symbol]
WATERMAIN	[Symbol]	STORM SEWER INTAKE	[Symbol]
STORM SEWER	[Symbol]	UNDERGROUND CONDUIT	[Symbol]
SANITARY SEWER	[Symbol]	HANDHOLE	[Symbol]
GAS LINE	[Symbol]	FIBER OPTIC VAULT	[Symbol]
ELECTRIC LINE	[Symbol]	FIBER OPTIC MANHOLE	[Symbol]
OVERHEAD ELECTRIC LINE	[Symbol]		

ESTIMATED PLOWING	ESTIMATED BORES	BACKHOE WORK	TRENCHING	MISC.	NOTES

AUREON PROJECT #2601.046

PROJECT NO. _____
GRINNELL, IOWA Sheet 1 of 2

#	REVISION	DATE	NAME	SCALE:

SCALE: 0' 15' 30' 60'

DATE: 1/29/2026

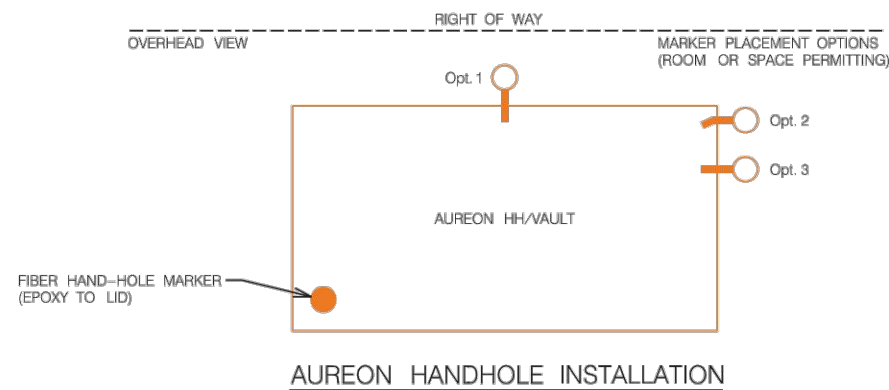
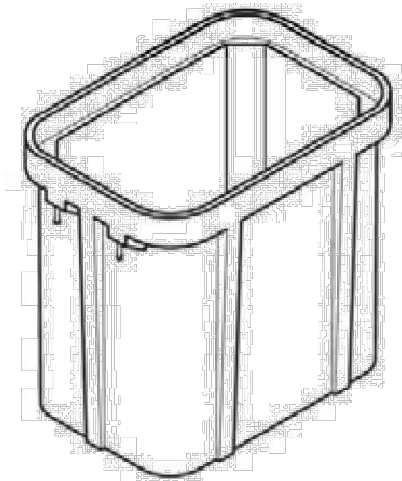
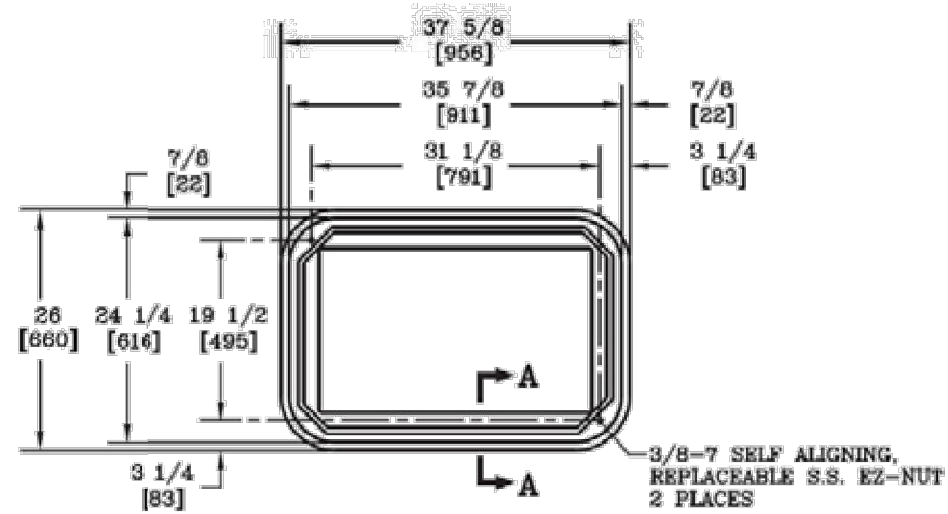
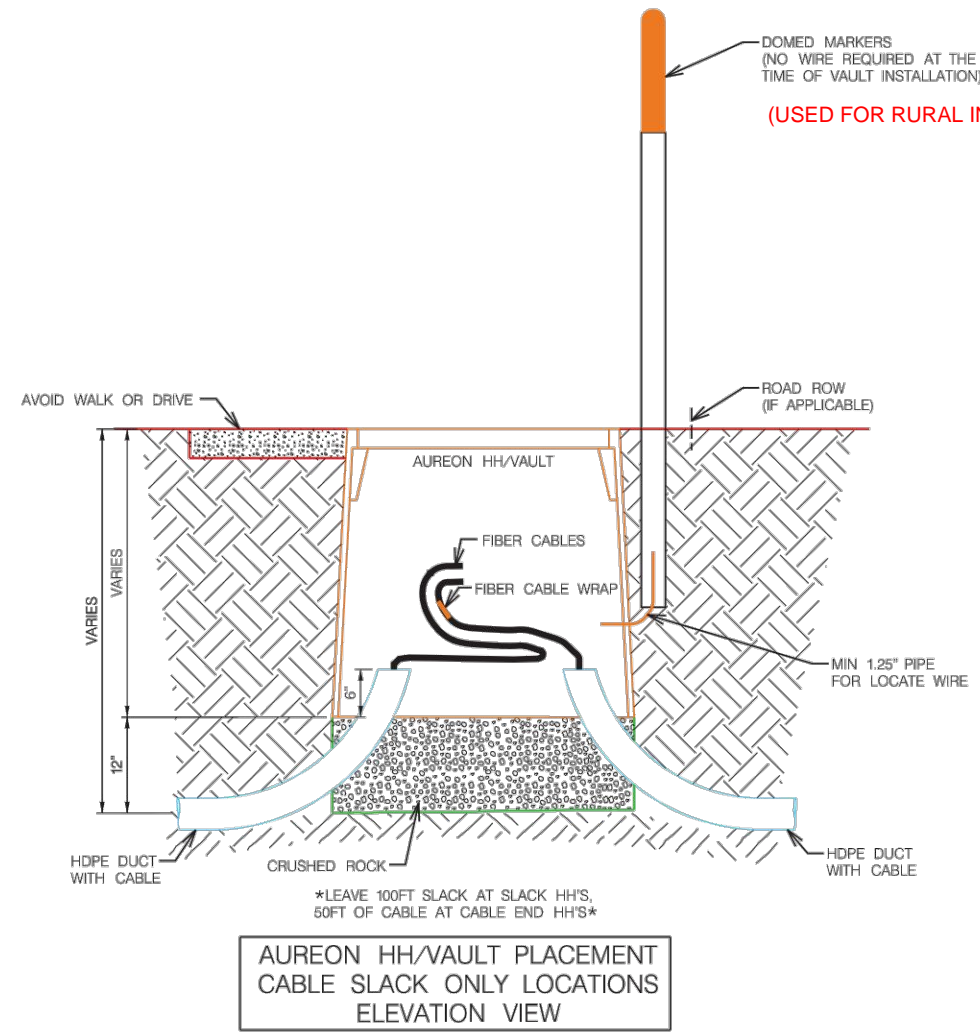

ESTIMATED PLOWING	ESTIMATED BORES	BACKHOE WORK	TRENCHING	MISC.	NOTES

AUREONTM

PROJECT NO. _____
Sheet

#	REVISION	DATE	NAME	SCALE:

DATE: _____

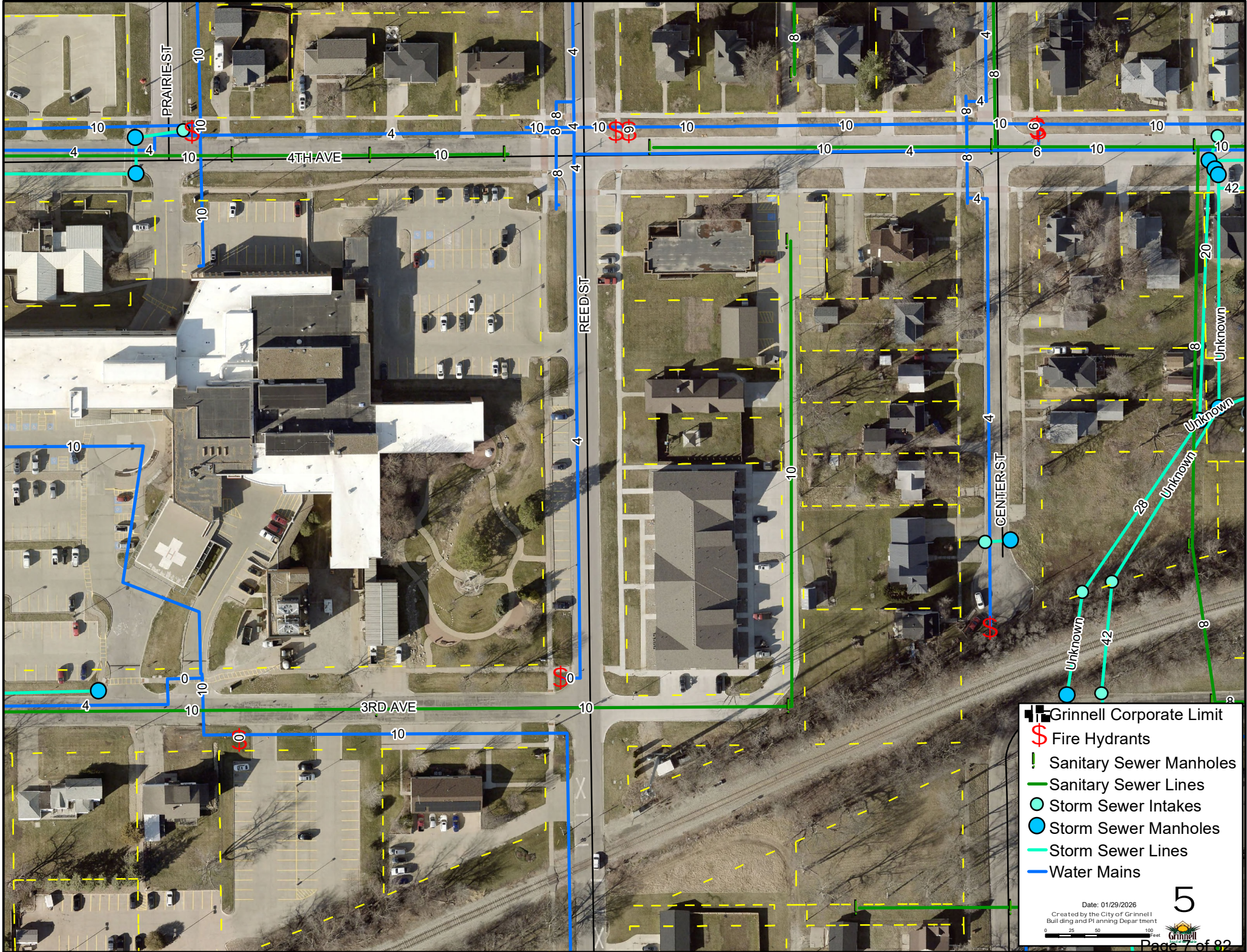

- Grinnell Corporate Limit
- Fire Hydrants
- Sanitary Sewer Manholes
- Sanitary Sewer Lines
- Storm Sewer Intakes
- Storm Sewer Manholes
- Storm Sewer Lines
- Water Mains

Date: 01/29/2026
 Created by the City of Grinnell
 Building and Planning Department



RESOLUTION NO. 2026-26

RESOLUTION SETTING PUBLIC HEARING ON PROPOSED PLANS, SPECIFICATIONS, AND FORM OF CONTRACT AND DIRECTING PUBLICATION OF NOTICE TO BIDDERS FOR THE CONSTRUCTION OF THE 2026 SEAL COAT PROJECT IN THE CITY OF GRINNELL, IOWA.

WHEREAS the proposed plans, specifications, and form of contract costs will be placed on file in the office of the City Clerk for the construction of the 2026 Seal Coat Project in the city of Grinnell, Iowa, as is fully set forth in the plans and specifications, and

WHEREAS the cost of the said improvement is in excess of the amount required to hold a public bid and a public hearing on the plans, specifications, form of contract and the estimated cost of said improvement is required by law and that notice thereof shall be given as required by law, and

NOW, THEREFORE, BE IT RESOLVED BY THE COUNCIL OF THE CITY OF GRINNELL, IOWA:

Section 1. This Council does hereby order the construction of 2026 Seal Coat Project in the city of Grinnell, Iowa, which public improvement is fully and particularly described in the plans and specifications, to be placed on file in the office of the City Clerk of Grinnell, Iowa.

Section 2. That the method of construction shall be by contract in accordance with the plans and specifications and general stipulations for said improvement approved by the City Council.

Section 3. All work under the proposed contract shall not be started before April 20, 2026, and shall be completed no later than June 15, 2026.

Section 4. The City Clerk is hereby directed to publish notice of hearing on plans, specifications, and form of contract in the manner provided by law for the public improvement outlined herein and that any person interested therein may appear and make objections thereto. The Council will meet in the Council Chambers at City Hall at 520 4th Avenue Grinnell, Iowa, at 7:00 pm local time on the 6th day of April 2026, for the purpose of hearing all of said objections so made and for taking final action upon the plans, specifications, and form of contract now on file.

Section 5. The City Clerk is further directed to advertise for bids in the manner provided by law for the construction of said improvements, setting forth in said notice such necessary pertinent information as will advise prospective bidders thereof together with the proposed manner of payment of the work to be constructed and that such bids be filed and received by the office of the City Clerk of Grinnell, Iowa, up to 1:30 pm, local time, on the 16th day of April 2026. The bids will be opened, read, and tabulated at that time and will be acted upon by the City Council of said City at a meeting to be held in the Council Chambers at City Hall at 520 4th Avenue Grinnell, Iowa, at 7:00 pm local time on the 16th day of April 2026.

Passed this 16th day of April 2026.

CITY OF GRINNELL, IOWA

SAM COX, MAYOR

ATTEST:

ERIENNE DOLL, DEPUTY CITY CLERK

CITY OF GRINNELL

**SPECIFICATIONS AND
CONTRACT DOCUMENTS**

FOR

**2026 SEAL COAT
PROJECT**

Prepared By:

City of Grinnell, Iowa

24 February 2026

Copy Number

DIVISION A

GENERAL DOCUMENTS

SECTION A-002 – TABLE OF CONTENTS

DIVISION A - GENERAL DOCUMENTS

SECTION 001 TITLE PAGE	A-001-1
SECTION 002 TABLE OF CONTENTS	A-002-1
SECTION 003 NOTICE OF HEARING AND LETTING	A-003-1 THRU 2
SECTION 004 INFORMATION TO BIDDERS	A-004-1 THRU 4
SECTION 005 FORM OF PROPOSAL	A-005-1 THRU 4
SECTION 006 NOTICE OF AWARD	A-006-1
SECTION 007 AGREEMENT	A-007-1 THRU 3
SECTION 008 FORM OF BID BOND	A-008-1 THRU 2
SECTION 009 FORM OF PERFORMANCE AND PAYMENT BOND	A-009-1 THRU 2
SECTION 010 NOTICE TO PROCEED	A-010-1
SECTION 011 PAYMENT REQUEST FORM	A-011-1

DIVISION B – GENERAL CONDITIONS OF THE CONTRACT

SECTION 001 CONTENTS AND DEFINITIONS	B-001-1 THRU 3
SECTION 002 INTERPRETATIONS	B-002-1 THRU 3
SECTION 003 CONTROL OF MATERIALS AND WORK	B-003-1 THRU 7
SECTION 004 LEGAL RELATIONS AND RESPONSIBILITIES TO THE PUBLIC	B-004-1 THRU 8
SECTION 005 MEASUREMENT AND PAYMENT	B-005-1 THRU 2
SECTION 006 TIME OF COMPLETION	B-006-1

DIVISION C – TECHNICAL PROVISIONS

SUBDIVISION C.1 – <u>BITUMINOUS SEAL COAT</u>	
SECTION 001 GENERAL SPECIFICATIONS	C.1-001-1
SECTION 002 TECHNICAL SPECIFICATIONS	C.1-002-1 THRU 2
SECTION 003 MATERIAL SPECIFICATIONS	C.1-003-1

END OF SECTION A-002

SECTION A-003 – NOTICE OF HEARING AND LETTING**PUBLIC HEARING****NOTICE OF PUBLIC HEARING ON PROPOSED PLANS, SPECIFICATIONS, AND FORM OF CONTRACT FOR THE 2026 SEAL COAT PROJECT IN THE CITY OF GRINNELL, IOWA, AND NOTICE TO BIDDERS FOR THE TAKING OF BIDS FOR SAID IMPROVEMENTS.**

Notice is hereby given that a public hearing will be held by the City Council of Grinnell, Iowa on April 6, 2026 at 7:00 P.M., in the Council Chambers on the second floor of the City Hall, 520 4th Avenue, Grinnell, Iowa 50112, on the plans, specifications, and proposed form of contract for street improvements and work incidental thereto as described in the plans and specifications therefore now on file in the office of the City Clerk. At said hearing, any interested person may appear and file objections thereto or to the cost of said construction.

Sealed proposals will be received at City Hall of the city of Grinnell, Iowa 520 4th Avenue, Grinnell, Iowa 50112, until 1:30 P.M., on April 16, 2026 for the 2026 Seal Coat Project as described in plans and specifications therefore now on file at the City Hall. Said proposals will be opened at a public meeting, to be held at 1:30 P.M., April 16, 2026 in the council chambers on the 2nd floor of City Hall, 520 4th Avenue. Said proposals will be acted upon by the City Council at the hearing, which is to be held at 7:00 P.M., on April 20, 2026.

The extent of the work involved is the furnishing of the supervision, equipment, labor, necessary services and material for the street improvements and related work located on the streets located in the City of Grinnell as shown on the 2026 Seal Coat Project map.

Each proposal shall be submitted on a blank proposal form as provided by the City and must be accompanied in a separate sealed envelope by a cashier's or certified check drawn on a bank in Iowa or a bank chartered under the Laws of the United States of America, or a certified share draft drawn on a Credit Union in Iowa or chartered under the Laws of the United States of America, or a bid bond, in an amount equal to five percent (5%) of the proposal. The bid security shall be made payable to the Treasurer of the City of Grinnell, Iowa. Such bid security shall be forfeited to the City as liquidated damages in the event the successful bidder fails or refuses to enter into a contract within ten (10) days after the award of contract or to post bond satisfactory to the City insuring the faithful fulfillment of the contract and maintenance of said work. Bid security of the lowest two or more bidders may be retained until a contract is awarded or rejection is made. Other bid security will be returned after the canvas and tabulation of bids is completed and reported to the City Council.

By virtue of statutory authority, preference will be given to products and provisions grown and coal produced within the State of Iowa and preference will be given to Iowa domestic labor in the said construction.

The successful bidder will be required to furnish a bond in the amount equal to one-hundred percent (100%) of the contract price, said bond to be issued by a responsible surety approved by the City Council, and shall guarantee the faithful performance of the contract in the terms and conditions therein contained, and shall guarantee the prompt payment of all materials and labor and protect and save harmless the City from claims and damages of any kind caused by the operation of the Contractor, and shall guarantee the maintenance of the construction for a period of ONE (1) year from and after its completion and acceptance by the City.

All work under the proposed contract shall not be started before April 20, 2026 and shall be completed no later than June 15, 2026

The plans, specifications, and proposed contract documents may be examined at the office of the City Clerk. Copies of said plans and specifications and Form of Proposal blanks may be secured at the office of the City Clerk, Grinnell, Iowa.

The City reserves the right to reject any and all proposals, waive technicalities and irregularities and to accept any proposal, which, in the opinion of the City Council, is deemed to be in the best interest of the City.

END OF SECTION A-003

SECTION A-004 – INFORMATION FOR BIDDERS

1. CONTRACT DOCUMENTS.

The Contract Documents are those listed as such in Article Six (6) of the Agreement, included herewith. Bidders must examine each of the Contract Documents, must visit the location of the work, and inform themselves of the conditions and make their own estimates of the facilities and difficulties attending the execution of the work.

2. DATE AND PLACE FOR OPENING PROPOSALS.

Pursuant to the “Advertisement,” proposals for performing the work shall be enclosed in a sealed envelope addressed to: City Clerk, City of Grinnell, Iowa, and endorsed:

PROPOSAL
2026 SEAL COAT PROJECT

Proposals shall be delivered to the City Offices, Grinnell, Iowa, until 1:30 P.M April 16, 2026 at which time and place such proposals will be opened, read, and tabulated for presentation to the City Council as stated in the “Advertisement.” The City Council will act on the proposals as stated in the “Advertisement” or at such later time as may be fixed.

3. PREPARATION OF PROPOSAL.

The proposal shall be legibly prepared with ink or typed on the blank Form of Proposal furnished by the City. THE FORM OF PROPOSAL BOUND IN THESE SPECIFICATIONS SHALL NOT BE USED FOR BIDDING. The bidder shall properly fill in all blank spaces provided in the proposal form, except for alternate items, on which the bidder is not required to bid. The unit price or lump sum bid shall be once stated in both words and figures, unless official proposal form does not provide for a place to write out price in words. The bidder shall specify a unit price for each of the separate items listed, except where a lump sum bid is called for. The bidder shall show the products of the respective quantities and unit prices in the column provided for that purpose and the sum for which the proposed work will be done. If a unit price or a lump sum bid already entered by the bidder on the proposal form is to be altered, it shall be crossed out in ink, the new unit price or lump sum bid entered above or below it and initialed in ink by the bidder. If there is a discrepancy between the amount written in words and amount in figures, the amount written in words shall control. The bidder, or a legally authorized agent, with the bidder’s full name and business address shall sign the Proposal. No bidder shall submit a proposal under an assumed title.

The bidder shall review the drawings and specifications of the project, and all other Contract Documents of same, and shall make a site inspection and be familiar with site conditions such

as accessibility, slopes, utilities, and any other conditions relevant to the construction of the project, prior to submitting a proposal. If any discrepancies between the drawings, specifications, other Contract Documents, and the site arise, the bidder shall ask for written clarification from the City before submitting a proposal. If the bidder feels there has been an omission in the drawings, specifications, or other Contract Documents, it shall be the bidder's responsibility to raise such opinions to the City Engineer, and the City shall reply to it before the bidder submits any proposal. The bidder shall be responsible for any damage or complications resulting from any neglect or failure to comply with this section. If the Bidder is awarded the contract, the Bidder (now the Contractor) shall be responsible for any damage or complications resulting from any neglect or failure to comply with this section throughout the construction process.

4. **DESIGNATED SALES TAX EXEMPT ENTITY.**

The City of Grinnell is a designed exempt entity. Designated exempt entities awarding construction contracts on or after January 1, 2003, may issue special exemption certificates to contractors and subcontractors allowing them to purchase or to withdraw from inventory construction materials for the contract free from sales tax.

The City of Grinnell is hereby notifying all potential bidders to submit their bids WITHOUT sales tax included. This policy will lower the dollar amount of the bid and the Contractor will not be required to provide Contractor Statements after the project is completed. The following steps will be used to complete this process:

- A. Designated exempt entities will register contracts, including information on contractors and subcontractors, through an online application developed by the Iowa Department of Revenue.
- B. Designated exempt entities will provide each contractor/subcontractor with an exemption certificate/authorization letter developed exclusively for this purpose. These will be printed directly from the online application. The letter/certificate can be obtained only through this application.
- C. Contractors and subcontractors will give a copy of the certificate to each of their material suppliers. This allows them to purchase building materials for the contract free from sales tax.
- D. Suppliers should retain this certificate in their records for at least three years.

5. **OMMISSIONS AND DISCREPANCIES.**

Should a bidder find discrepancies in, or omissions from, the drawings or Contract Documents, or should be in doubt as to their meaning, the bidder shall at once notify the City, who may send a written instruction to all bidders.

6. ACCEPTANCE OR REJECTION OF PROPOSALS.

The City of Grinnell reserves the right to reject any or all bids, waive informalities, or accept any bid it may deem best.

7. CERTIFIED CHECK.

A certified check or bid bond acceptable must accompany each bid to the City of Grinnell, in an amount of five percent (5%) of the bid amount. Checks shall be made payable to the order of the City Treasurer, such check to be returned to the bidder unless forfeited under the conditions herein stipulated. All such deposits, including that of the successful bidder, shall be returned to the bidders after execution of the project, or in case all bids are rejected, after such rejection.

8. ACCEPTANCE OF PROPOSALS AND ITS EFFECTS.

The City Council will act upon the proposals within ten (10) days after the bid opening date. The acceptance of a proposal will be a notice in writing signed by a duly authorized representative of the City of Grinnell, and no other act shall constitute the acceptance of a Proposal. Such acceptance shall bind the successful bidder to execute the Contract and to be responsible for liquidated damages for failure to execute, as provided in Paragraph Eight (8) below. The rights and obligations provided for the Contract shall become effective and binding upon the parties only with its formal execution.

9. SUBSTITUTIONS.

All items of material or equipment proposed by the Contractor as equal substitutions for items of material or equipment, which is specified, shall be equal in every respect to the quality, quantity, performance, color, finish, gauge, and size of that item which has been used as a basis of quality. When certain manufacturer's equipment is given as a standard of quality, than all accessories that are standard on that item of equipment must be furnished even though the accessories may not be standard on some substituted equipment of another manufacturer.

The Engineer shall be the sole and final judge as to the suitability of substituted items. The Contractor shall furnish and install the specified items when proposed substitutions are not accepted. The entire cost of all changes, of any type, necessitated by substitutions of specified material or equipment shall be borne by the Contractor making the substitution. The successful Bidder shall, within fourteen (14) days after receiving the Notice to Proceed, submit to the Engineer a complete list of items and material and equipment the Bidder is proposing to use on this Contract. The list shall be complete with manufacturer's names, size, and types. Equipment orders shall not be placed until shop drawings have been reviewed. Four (4) copies of the list shall be furnished; one of which will be returned with the Engineer's comments. Where materials in the submittal differ from those specified, complete data shall be furnished to the Engineer as listed below. Requests will be considered only if they comply

with all of the following requirements. Complete technical data, including lab reports, if applicable, must be submitted. The differences, including operation, physical dimensions, etc., between proposed products and specified products shall be fully explained. Complete information shall be submitted in regard to any changes required on the drawings or specifications for related work. Any difficulties, delays, or additional expenses, which arise from changes due to substitutions, shall be the responsibility of the Contractor. Items furnished under any “OR Equal” clause will be considered substitutions and, to the extent required by the Engineer, must comply with this article.

10. TIME FOR EXECUTING CONTRACT AND DAMAGES FOR FAILURE.

Any bidder whose proposal shall be accepted will appear at the office of the City Clerk of the City of Grinnell, Iowa, in person, or, if a firm or corporation, a duly authorized representative shall so appear, to present the required bonds, and proof of insurance, and to execute the contract within ten (10) days after notice that the contract has been awarded. Failure or neglect to do so shall constitute a breach of the agreement affected by the acceptance of the proposal.

11. TIME FOR COMPLETION OF WORK.

The contractor shall complete the work by the date stated in the “Advertisement.” Attention is respectfully called to the provisions for liquidated damages and other actual damages as set out in Article Two (2) of the Agreement. Completion time is subject to extensions as provided in the “General Conditions.”

12. INTERPRETATIONS AND ADDENDA.

No oral interpretations shall be made to any bidder as to the meaning of any of the contract documents, or be effective to modify any of the provisions of the contract documents. Every request for an interpretation shall be made in writing and addressed and forwarded to the City Engineer.

13. POSTPONEMENT OF BID OPENING.

The City Council reserves the right to postpone the date for presentation and opening of proposals and will give registered mail, facsimile transmittal, or telegraphic notice of any such postponement to each prospective bidder.

END OF SECTION A-004

A-005 FORM OF PROPOSAL

DO NOT REMOVE FROM THIS BOOK

PROPOSAL OF: _____

TO: _____

City Council:

The undersigned bidder has carefully examined an official copy of the Contract Documents prepared for the above noted project, which documents are referred to in the “Information to Bidders,” and has also examined the site of the work, and this proposal is submitted in accordance with the acceptance of such conditions and requirements and with applicable laws and ordinances.

The undersigned bidder will provide all the necessary labor, machinery, tools, apparatus, and other means of construction, and do all the work, and furnish all the materials called for in the contract documents, in the manner prescribed therein, and in accordance with the requirements of the City for a total consideration based on the lump sum figures and/or unit prices stated in the bid schedule below.

The undersigned bidder also agrees as follows if the City as a basis accepts this Proposal for a Contract:

- (1) To do any extra work, not covered by the schedule of prices offered herein, which may be ordered by the City, and to accept as full compensation therefore such prices as may be agreed in writing by the City and the undersigned in accordance with the “General Conditions.”
- (2) To sign the prescribed Form of Contract and furnish the required Owner’s Performance Bond and file evidence of compliance with insurance requirements

within ten (10) days after acceptance of this Proposal or forfeit the proposal guarantee submitted herewith. To finish and complete work on or before the date specified in the “Notice of Hearing and Letting.”

- (3) To pay the City as fixed and liquidated damages \$100.00 for each and every calendar day elapsing after the specified completion date and before actual completion of the work to a degree acceptable to the City.
- (4) To reimburse the City, by a reduction of the final payment due the Contractor, an amount equal to the charges made for engineering services incurred because of continuance of the work beyond the specified completion date.
- (5) To accept as full payment for the completed work an amount based on prices offered herein and on the actual measured work completed and subject to prescribed adjustments due to changes officially ordered during the progress of the work.

The undersigned bidder understands that the City Council may reject any or all proposals, waive irregularities, or accept any bid, which in the opinion of the City Council is deemed to be in the best interest of the City.

The undersigned bidder understands that the quantities of work shown herein are approximate only and are subject to increase or decrease, at the unit prices stated in the following schedule.

The receipt of addendum number ____, ____, ____, and ____ are hereby acknowledged.

BID SCHEDULE - STREETS

ITEM	DESCRIPTION	QUANTITY	UNITS	UNIT PRICE	TOTAL PRICE
1.	BINDER BITUMEN ASPHALT MC3000 SINGLE COAT	21,139	SQ YDS		
2.	Grind and Relay Asphalt MC3000 Double Coat	5635	SQ YDS		
	TOTAL AMOUNT				

A certified check or bid bond in the sum of five percent (5%) of the total price accompanies this proposal under separate cover and it its hereby agreed that in case of failure on the part of the undersigned to execute the contract and give satisfactory surety bond within ten (10) days after the acceptance of this proposal, said certified check or bid bond shall be forfeited to the City as liquidated damages for such failure, otherwise the certified check or bid bond shall be returned to the undersigned.

Signed and sealed this _____ day of _____, 2026.
(If the bidder is an individual, partnership, or non-incorporated organization, sign and complete the following:)

Signature of Bidder _____

By _____

Address _____

Names and Addresses of members of the Firm: _____

(If the bidder is a corporation, sign and complete the following:)

Signature of Bidder _____

By _____

Business Address _____

Incorporated under the laws of the State of _____

Name of Officers: President _____

Secretary _____

Treasurer _____

END OF SECTION A-005

SECTION A-006 - NOTICE OF AWARD

To: _____
ATTN:

The City Council of the City of Grinnell, Iowa has considered the proposal submitted by you on April 16, 2026 in the City of Grinnell, Iowa.

It appears that it is to the best interest of the City of Grinnell to accept your proposal in the amount of: _____), you are hereby notified that your proposal has been accepted for the 2026 Seal Coat Project subject to completion of financing and approval of the contract. You are required by the “Notice of Hearing and Letting” to execute the formal contract with the City of Grinnell and to furnish the required Contractor’s performance and payment bond within the terms specified in the “Notice of Hearing and Letting.”

If you fail to execute said contract and to furnish said bonds within ten (10) days from the date of delivery of this “Notice of Award,” the City of Grinnell will be entitled to consider all your rights arising out of the City of Grinnell’s acceptance of your proposal as abandoned and to award the work covered by your proposal to another, or to re-advertise the work, or as the City Council deems to be in the best interest of the City of Grinnell.

Dated this _____ day of April, 2026.

City of Grinnell, Iowa:

By: _____

Sam Cox, City Mayor

Acceptance of Notice: Receipt of Above
“Notice of Award” is hereby acknowledged this _____ day of _____, 2026.

Contractor:

By: _____

Title: _____

END OF SECTION A-006

SECTION A-007 – AGREEMENT

This Agreement made the _____ day of April in the year Two Thousand and Twenty-six, hereinafter called the Contractor, and the City of Grinnell, Iowa hereinafter called the City.

WITNESSETH, that the Contractor and City for the consideration hereinafter named agree as follows:

ARTICLE 1. SCOPE OF WORK.

The Contractor shall furnish all material, superintendence, labor and equipment unless otherwise specified and shall defray such other costs as are necessary to complete in a proficient manner to the satisfaction and acceptance of the City Engineer, of Grinnell, the work required by the Contract Documents, as listed in Article Six (6) of this Agreement, the General Conditions of the Contract, the Specifications, and the Drawings.

ARTICLE 2. TIME OF COMPLETION.

The work to be performed under this contract shall be carried on regularly and uninterruptedly (unless the said Engineer or City shall otherwise, in writing, especially direct) with such force as to insure the full completion within the time specified with the Advertisement. If the Contractor shall fail to complete the work in the time above-specified, or within such further time as, in accordance with the provisions of these Contract Documents, shall be fixed or allowed for such completion, the sum of \$100.00 per day shall be deducted from the sum due to the Contractor under this Contract as liquidated damages. In view of the difficulty of estimating such damages, the sum of \$100.00 per day is hereby agreed upon, fixed, and determined by reason of default, and not by way of penalty. Such Liquidated Damages are intended as compensation for delay only and the retention or recovery of such damages by the City shall not prevent the recovery of other actual damage sustained by the City, constitute a defense to any action brought by the City based on alleged breach of contract, or to compel specific performance of the contract, or in any way affect the terms, conditions or liability of the performance bonds to be furnished by the contractor.

ARTICLE 3. THE CONTRACT SUM.

In consideration of the work described herein and the fulfillment of all stipulations of this Contract, subject to additions and deductions provided therein, the City shall pay to the Contractor the amount due to the Contractor, based on prices contained hereinbefore in Section A-005, entitled FORM OF PROPOSAL.

ARTICLE 4. PROGRESS PAYMENTS.

The City shall make partial payments to the Contractor on the basis of a duly certified approved estimate of value, by the Engineer, based on the Contract prices, of labor and materials incorporated in the work, and of timely materials suitably stored at the site thereof up to the twentieth (20) day of that month, less the aggregate of previous payments. The City will retain five percent (5%) as may be deemed advisable by the Engineer, until final completion and acceptance of all work covered by the contract.

ARTICLE 5. ACCEPTANCE AND FINAL PAYMENT.

The work called for under this contract shall be subject to review and final inspection. Upon receipt of written notice that the work is ready for final inspection and acceptance, the Engineer shall promptly make such inspection, and when the Engineer finds the work acceptable under the Contract and the Contract fully performed, the Engineer shall promptly issue a final certificate, over the Engineer's own signature, stating that the work provided for this Contract has been completed and is acceptable under the terms and conditions thereof, and the entire balance found to be due to the Contractor, including the retained percentage, shall be paid to the Contractor not sooner than thirty (30) days after the date of acceptance of the work by the City Council of the City of Grinnell. At the time the Contractor requests a final certificate, the Contractor shall submit an affidavit to the Engineer that all payrolls, material bill, and other indebtedness connected with the work have been paid.

ARTICLE 6. THE CONTRACT DOCUMENTS.

Each of the documents listed below and all modifications thereof incorporated in the documents before their execution shall form the Contract, as if hereto attached or herein repeated.

2026 SEAL COAT PROJECT SPECIFICATIONS AND CONTRACT DOCUMENTS, published by the City of Grinnell, March 16, 2026, and all those documents therein listed, INCLUDING:

DIVISION A – GENERAL DOCUMENTS

DIVISION B – GENERAL CONDITIONS OF THE CONTRACT

DIVISION C – TECHNICAL PROVISIONS

This agreement shall be binding upon the legal representative and successors of the parties respectively.

IN WITNESS WHEREOF, the parties hereto have hereunto set their hands and seals on the day and year first above written.

Name of Individual or Partnership

By: _____

Signed in the Presence of: _____

Name of Corporation

By: _____ as its _____

By: _____ as its _____

Signed in the Presence of: _____

City of Grinnell
Name of City

By: _____, Sam Cox, Mayor

By: _____ Alyssa Devig, City Clerk

END OF SECTION A-007

SECTION A-008 – FORM OF BID BOND

KNOW ALL PEOPLE BY THESE PRESENT that we _____
_____ as Principal, and _____
_____ as Surety, are held and firmly bound unto the City
of Grinnell, Iowa. Hereinafter called the “Owner” in the penal sum of _____
_____ Dollars,
(\$ _____) lawful money of the United States of America for the payment
of which sum will and truly be made, we bind ourselves, our heirs, executors,
administrators, and successors, jointly and severally, firmly by these present. The
condition of this obligation is such that whereas the Principal has submitted the
accompanying bid, dated _____, 2026, for the 2026 Seal Coat Project.

NOW, THEREFORE,

- (a) If said Bid shall be rejected, or in the alternate,
- (b) If said Bid shall be accepted and the Principal shall execute and deliver a contract in the form specified and shall furnish a bond for the faithful performance of said contract, and for the payment of all persons performing labor or furnishing materials in connection therewith, and shall in all other respects perform the agreement created by the acceptance of said bid, then this obligation shall be void, otherwise the same shall in force and effect; it being expressly understood and agreed that the liability of the Surety for any and all claims hereunder shall, in no event, exceed the penal amount of this obligation as herein stated.

By virtue of statutory authority, the full amount of this bid bond shall be forfeited to the Owner in liquidation of damages sustained in the event that the Principal fails to execute the contract and provide the bond as provided in the specification or by law.

The Surety, for the value received, hereby stipulates and agrees that the obligations of said Surety and its bond shall be in no way impaired or

affected by any extension of the time within which the Owner may accept such bid or execute such contract; and said surety does hereby waive notice of any such extension.

IN WITNESS WHEREOF, the principal and the surety hereto set their hands and seals, and such of them as corporations, have cause their corporate seals to be hereto affixed and these present to be signed by their proper officers this _____ day of _____, 2026, A.D.

Witness

Principal

By: _____ (Title)

(Seal)

Surety

By: _____

(Attorney-in-fact)

Attach Power of Attorney

END OF SECTION A-008

SECTION A-009 – FORM OF PERFORMANCE, PAYMENT AND MAINTENANCE BOND

KNOW ALL PEOPLE BY THESE PRESENT, that we, _____, (hereinafter called the Principal) and _____, (hereinafter called the Surety), are held and firmly bound unto the City of Grinnell, Iowa, (hereinafter called the Owner), in the penal sum of _____ Dollars (\$ _____) lawful money of the United States of America to the payment of which sum will and truly be made, the Principal herein firmly binds him/her/themselves, their heirs, executors, and administrators, and the Surety bind themselves, their successors, assigns, executors, and administrators, and successors, jointly and severally, firmly by these present.

THE CONDITION OF THIS OBLIGATION IS SUCH, THAT whereas the above bonded Principal, did on the _____ day of _____, 2026, enter into a written contract with the City of Grinnell to do the 2026 Seal Coat Project as specified in the Contract Documents,

NOW, THEREFORE, if said Principal shall faithfully perform said contract, and if the said Principal shall warrant all workmanship and materials for a period of one (1) year from the final inspection and acceptance date, then this obligation shall be void; otherwise, it shall remain in full force and effect. Copy of which contract, together with all of its terms, covenants, conditions, and stipulations is incorporated herein and made a part hereof as fully and completely as if said contract were received at length herein and,

WHEREAS, the Principal and Sureties on this bond hereby agree to pay all persons, firms, or corporations having contracts directly with the Principal or with subcontractors, all just claims due them for labor performed or materials furnished in the performance of the contract on account of which this bond is given, when the same are not satisfied out of the portion of the contract price which the Owner is required to retain until completion of the improvements, but the principal and sureties shall not be liable to said persons, firms, or corporations unless the claims of said claimants against said portion of the contract price shall have been established as provided by law.

Now if the Principal shall in all respects fulfill the said contract according to the terms and tenor thereof, and shall satisfy all claims and demands incurred for the same; and shall fully indemnify and save harmless the Owner from all costs and damages which it may suffer by reason of failure to do so and shall full reimburse and repay the Owner all outlays and expenses which it may incur in making good and such default, then the obligation is to be void and of no effect; otherwise to remain in full force and effect.

Every surety on this bond shall be deemed and held, any contract to the contrary notwithstanding, to consent without notice,

1. To any extension of time to the contractor in which to perform to the contract.
2. To any change in the plans, specifications, or contract, when such changes does not involve an increase of more than twenty percent (20%) of the total contract price, and shall then be released only as to such excess increase.
3. That no provisions of this bond or of any other contract shall be valid which limits to less than one (1) year from the time of the acceptance of the work the right to sue on this bond for defects in workmanship or material not discovered or known to the Owner at the time such work is accepted.

IN WITNESS WHEREOF, we have hereunto set our hands and seal this _____ day of _____, 2026.

Principal

By: _____

Surety

By: _____
Attorney-in-fact Iowa Resident Agent

END OF SECTION A-009

SECTION A-010 – NOTICE TO PROCEED

Date: , 2026

Contractor:

Attention:

Subject: Notice to Proceed with the Construction of the 2026 Seal Coat Project.

Dear:

You are hereby directed to proceed with the construction of the above-mentioned project in accordance with the terms of the Contract Documents, plans, and specifications entered into by:

Contractor: _____ and the city of Grinnell

The signed contract is dated _____ 2026. The stipulated time for commencing work on the project is _____, 2026 and the completion is in accordance with the contract terms.

Sincerely yours,

City of Grinnell

By:

Title: Public Services Director

END OF SECTION A-010

SECTION A-011 – PAYMENT REQUEST FORM

The Contractor shall submit this form to the City of Grinnell by the 20th day of each month. Work done up to and on that day may be included in that months pay request.

Copies of this form shall be made by the Contractor, and filled out and submitted by the 20th of each month. The City shall then process the request, and submit this request to the City Council at their first meeting of the following month.

I/We, the undersigned, as Contractor for the 2026 Seal Coat Project, hereby submit and request payment for the work done to date, and for materials on hand, as listed below.

_____ Date

_____ Name of Individual or partnership

By: _____

_____ Name of Corporation

By: _____ as its _____

Quantities and amounts approved / as corrected / as submitted / as changed by:

_____ Date

City of Grinnell
_____ Name of City

By: _____, Russ Behrens, City Manager

Approved for payment as submitted / as changed by:

_____ Date

City of Grinnell
_____ Name of City

By: _____, Sam Cox, Mayor

By: _____, Alyssa Devig, City Clerk

DIVISION B

GENERAL CONDITIONS OF THE CONTRACT

DIVISION B – GENERAL CONDITIONS OF THE CONTRACT

SECTION 001 - CONTENTS AND DEFINITIONS

SECTION 002 - INTERPRETATIONS

- 2.1 INTENT OF THE CONTRACT DOCUMENTS
- 2.2 CONTRACTOR'S UNDERSTANDING
- 2.3 DRAWINGS AND INSTRUCTIONS
- 2.4 CONFLICT
- 2.5 DIMENSIONS
- 2.6 DRAWINGS AND SPECIFICATIONS AT JOB SITE
- 2.7 SURVEYS, PERMITS, AND REGULATIONS
- 2.8 ROYALTIES AND PATENTS
- 2.9 CHANGES IN THE WORK

SECTION 003 - CONTROL OF MATERIALS AND WORK

- 3.1 ENGINEER'S STATUS
- 3.2 INSPECTION OF WORK
- 3.3 AUTHORITY AND DUTIES OF INSPECTOR
- 3.4 SUPERINTENDENCE AND SUPERVISION
- 3.5 SUBCONTRACTS
- 3.6 SEPARATE CONTRACTS
- 3.7 CONFORMITY WITH EXISTING STRUCTURES
- 3.8 MATERIALS AND EQUIPMENT
- 3.9 STORAGE OF MATERIALS
- 3.10 MANUFACTURER'S DIRECTIONS
- 3.11 SHOP DRAWINGS
- 3.12 ORDER OF CONSTRUCTION
- 3.13 PROGRESS
- 3.14 SUSPENSION OF WORK
- 3.15 CONSTRUCTION REPORTS
- 3.16 HOURS OF WORK
- 3.17 WEATHER
- 3.18 WORKERS AND EQUIPMENT
- 3.19 REMOVAL OF UNAUTHORIZED OR DEFECTIVE WORK
- 3.20 CORRECTION OF WORK AFTER FINAL PAYMENT
- 3.21 CLEANING UP

SECTION 004 – LEGAL RELATIONS AND RESPONSIBILITIES TO THE PUBLIC

- 4.1 CONTRACT SECURITY
- 4.2 INSURANCE
- 4.3 LAWS RELATING TO WORK
- 4.4 PROTECTION OF WORK AND PROPERTY
- 4.5 ACCIDENT PREVENTION AND RESPONSIBILITY FOR ACCIDENT
- 4.6 MAINTENANCE OF BARRICADES AND LIGHTS
- 4.7 LANDS FOR WORK
- 4.8 SANITARY CONVENIENCES
- 4.9 LIENS
- 4.10 ASSIGNMENT
- 4.11 CLAIMS AGAINST CONTRACTOR
- 4.12 PERSONAL LIABILITY OF PUBLIC OFFICIALS
- 4.13 NO WAIVER OF LEGAL RIGHTS
- 4.14 USE OF COMPLETED PORTIONS
- 4.15 MATERIALS FOUND ON THE WORK
- 4.16 CITY'S RIGHT TO DO WORK
- 4.17 CITY'S RIGHT TO CORRECT DEFICIENCIES
- 4.18 CITY'S RIGHT TO TERMINATE CONTRACT
- 4.19 CONTRACTOR'S RIGHT TO SUSPEND WORK
- 4.20 REMOVAL OF EQUIPMENT
- 4.21 ENGINEER'S DECISIONS

SECTION 005 – MEASUREMENT AND PAYMENT

- 5.1 STANDARDS OF MEASUREMENT
- 5.2 USE OF CITY WATER
- 5.3 CLAIMS FOR EXTRA COST
- 5.4 BASIS FOR PAYMENT
- 5.5 DEDUCTIONS FOR UNCORRECTED WORK
- 5.6 TAXES

SECTION 006 – TIME OF COMPLETION

- 6.1 EXTENSIONS OF TIME

SECTION B-001 – DEFINITIONS

Contract Documents are those listed as such in Article Six (6) of the Agreement, included herewith.

Plans and Drawings refer to the plans as specified in Article Six (6) of the Agreement, included herewith.

Specifications shall mean the same as if the term Contract Documents had been used in its place.

Contract is the agreement covering the performance of the work described in the Contract Documents, including all supplemental agreements thereto, and all general and specific provisions pertaining to the work or materials therefore.

The City and **The Contractor** are those mentioned as such in the Agreement. They are treated throughout the Contract Documents as if each were of the singular number.

Wherever the word **Engineer** is used in the Contract, it shall be understood as referring to the City Engineer of the City of Grinnell, acting personally or through an assistant duly authorized for such act by the Engineer or by the City Manager.

Surety is the person, firm, or corporation who executed the Performance Bond.

The term **Subcontractor**, as employed herein, includes only those having a direct contract with the Contractor and it includes one who furnishes material worked to a special design according to the plans or specifications of this work, but does not include one who merely furnishes material not so worked.

Written Notice shall be deemed to have been duly served if delivered in person to the individual, a member of the firm, or to an officer of the corporation for whom it is intended, or if delivered at or sent by registered mail to the last known business address for whom it is intended by the sender of the notice.

The term "**Work**" of the Contractor or Subcontractor includes labor, materials, equipment, transportation, or other facilities and activities necessary to complete the Contract, either individually or in any combination thereof.

END OF SECTION B-001

SECTION B-002 -- INTERPRETATIONS

2.1 INTENT OF THE CONTRACT DOCUMENTS.

The intent of the Contract Documents is to provide for the construction and completion of every detail of the improvements included in the Contract. What is called for by any one shall be as binding as if called for by all. It is understood that the Contractor, for the Contract Price, will furnish all labor, materials, tools, transportation, and supplies, and will execute the Contract in a satisfactory and worker like manner, and in accordance with the plans, specifications, and terms of the Contract.

2.2 CONTRACTOR'S UNDERSTANDING.

It is understood and agreed that the Contractor has, by the Contractor's own careful and active examination, been satisfied as to the nature and location of the work, the conformation of the ground, the character, quality, and quantity of the materials to be encountered above and below ground, the character of equipment and facilities needed preliminary to and during the prosecution of the work, the general and local conditions, and all other matters which can in any way effect the work under this Contract. No verbal agreements or conversations with any officer, agent, or employee of the City, either before or after the execution of this Contract, shall affect or modify any of the terms or obligations herein contained.

2.3 DRAWINGS AND INSTRUCTIONS.

The Engineer will furnish to the Contractor, free of charge, up to ten (10) copies of drawings and specifications necessary for the execution of the work. Additional sets desired by the Contractor will be available for the cost of materials and labor to provide such copies. The Engineer shall also furnish, with reasonable promptness, additional instructions, by means of drawings or otherwise, necessary for the proper execution of the work. All such drawings and instructions shall be consistent with the Contract Documents, true development thereof, and reasonably inferable therefrom.

2.4 CONFLICT.

If there be conflicting variance between the Drawings and the Specifications, the provisions of the Specifications shall control. In case of conflict between the General Conditions of the Contract, or any additions thereof, and the Detailed Specifications, the Detailed Specifications shall control. Terms of any Special Conditions included in this specification as a result of Federal or State funding of the project shall take precedence over these General Conditions.

2.5 DIMENSIONS.

Figured dimensions or datum deviations on the Plans shall be used in lieu of scaling the Drawings. Where the work of the Contractor is affected by finished dimensions, these shall be determined by the Contractor at the site, and the Contractor shall assume the responsibility therefore.

2.6 DRAWINGS AND SPECIFICATIONS AT JOB SITE.

One complete set of all Drawings and Specifications shall be maintained at the job site by the Contractor, and shall be available to the Engineer at all times.

2.7 SURVEYS, PERMITS, AND REGULATIONS.

The City shall furnish all surveys unless otherwise specified. Permits of a temporary nature necessary for the prosecution of the work shall be secured by the Contractor. Permits and easements for permanent structures or permanent changes in existing facilities shall be secured by the City, unless otherwise specified.

2.8 ROYALTIES AND PATENTS.

The Contractor shall pay all royalties and license fees. The Contractor shall defend all suits or claims for infringement of any patent rights and shall save the City harmless from loss on account thereof, except that the City shall be responsible for all such loss when a particular process or the product of a particular manufacturer or manufacturers is specified, but if the Contractor has information that the process or article specified is an infringement of a patent, the Contractor shall be responsible for such loss unless such information is promptly given to the Engineer.

2.9 CHANGES IN THE WORK.

The City, without invalidating the Contract, may order extra work or make changes by altering, adding to or deducting from the work, the Contract sum being adjusted accordingly. All such work shall be executed under the conditions of the original Contract except that any claims for extension of time caused thereby shall be adjusted at the time of ordering such change. No allowance shall be made for anticipated profit on work not performed.

In giving oral instructions, the Engineer shall have the authority to make minor changes in the work, not involving extra cost, and not inconsistent with the purposes of the work, but otherwise, except in an emergency endangering life or property, no extra work or change shall be made unless in pursuance of a written order by the Engineer, and no claim for an addition to the Contract Sum shall be valid unless so ordered.

The value of any such extra work or change shall be determined in one or more of the following ways:

- (a) By estimate and acceptance in a lump sum.
- (b) By unit prices named in the Contract or subsequently agreed upon.
- (c) By cost and percentage.
- (d) By cost and a fixed fee.

If none of the above methods is agreed upon, the Contractor, having received an order as described above, shall proceed with the work. In such case and also under cases (c) and (d), the Contractor shall keep and present in such form as the Engineer may direct, a correct account of the net cost involved in the change, together with vouchers. The net cost shall include labor, materials, equipment, and insurance, to the exclusion of other items, which shall be classed as overhead. In any case, the Engineer shall certify to the amount due to the Contractor, including reasonable allowance, not to exceed fifteen percent (15%) of the net cost, for overhead and profit. Pending final determination of value, payments on account of changes shall be made on the Engineer's estimate.

END OF SECTION B-002

SECTION B-003 -- CONTROLS OF MATERIALS AND WORK

3.1 ENGINEER'S STATUS.

The Engineer has the authority to stop work whenever such stoppage may be necessary to insure the proper execution of the Contract. The Engineer shall also have authority to reject all work and materials, which do not conform to the Contract.

3.2 INSPECTION OF WORK.

The Engineer and the Engineer's representatives, and representatives from the Iowa Department of Natural Resources and the Environmental Protection Agency, shall at all times have access to the work whenever it is in preparation or progress and the Contractor shall provide proper facilities for such access and for inspection.

If the specifications, the Engineer's instructions, laws, ordinances or any public authority require any work to be specially tested or approved, the Contractor shall give the Engineer timely notice of its readiness for inspection, and if the inspection is by another authority than the Engineer, of the date fixed for such inspection. Inspections by the Engineer shall be promptly made, and where practicable at the source of supply. If any work should be covered up without approval or consent of the Engineer, it must, if required by the Engineer, be uncovered for examination at the Contractor's expense.

Re-examination of questioned work may be ordered by the Engineer, and if so ordered, the work must be uncovered by the Contractor. If such work were found in accordance with the Contract Documents, the City shall pay the cost of re-examination and replacement. If such work be found not in accordance with the Contract Documents, the Contractor shall pay such cost, unless the Contractor shall show that the defect in the work was caused by another Contractor, who is not a subcontractor of the Contractor, and in that event, the City shall pay such cost.

3.3 AUTHORITY AND DUTIES OF INSPECTOR.

Inspectors may be stationed on the work to report to the Engineer as to the progress of the work, manner in which the work is being performed, also to report whenever it appears that materials furnished and worked performed by the Contractor fails to fulfill the requirements of the specifications and contract, and to direct the attention of the Contractor to such failure or infringement, but such inspection shall not relieve the Contractor from any obligations to furnish acceptable materials or to provide completed construction that is satisfactory in every particular.

In case of any dispute arising between the Inspector and the Contractor as to material furnished or the manner of performing the work, the Inspector shall have the authority to reject materials or suspend the work until the question at issue can be referred to and decided by the Engineer. Inspectors are not authorized to revoke, alter, enlarge, relax, or release any requirements of these specifications. The Inspector shall in no case act as supervisor or perform other duties for the Contractor, or interfere with the Management of the work by the Contractor. The responsibility for omissions and defective materials or workmanship lies with the Contractor, and the presence of the Engineer or Inspector during construction does not alter the Contractor's responsibility.

3.4 SUPERINTENDENCE AND SUPERVISION.

The Contractor shall keep on the work site, during the work's progress, a competent superintendent and any necessary assistants, all satisfactory to the Engineer. The superintendent shall represent the Contractor in the Contractor's absence, and all directions given to the superintendent shall be as binding as if given to the Contractor. Important directions shall be confirmed in writing to the Contractor. Other directions shall be so confirmed on written request by the Contractor. The Contractor shall give efficient supervision to the work, using the best skill and attention.

If the Contractor, in the course of the work, finds any discrepancy between the drawings and the physical conditions of the locality, or any errors or omissions in the drawings, or in the layout as given by points and instructions, it shall be the Contractor's duty to immediately inform the Engineer, in writing, and the Engineer shall promptly verify the same. Any work done after such discovery, until authorized, will be done at the Contractor's risk.

Should any change result in increased cost to the Contractor, the value of any such change shall be determined as provided for in Section B-002 under "Changes in the Work."

3.5 SUBCONTRACTS.

The Contractor shall, as soon as practicable after execution of the Contract, but prior to the beginning work, notify the Engineer in writing of the names of subcontractors proposed for the work and shall not employ any that the Engineer may, within a reasonable time, object to as incompetent or unfit.

The Contractor agrees to be fully responsible to the City for the acts and omissions of the subcontractors and of persons either directly or indirectly employed by them, as the Contractor is responsible for the acts and omissions of persons directly employed by the Contractor.

Nothing contained in the Contract Documents shall create any contractual relation between any subcontractor and the City.

3.6 SEPARATE CONTRACTS.

The City reserves the right to let other contracts in connection with this work. The Contractor shall afford other contractors reasonable opportunity for the introduction and storage of their materials and the execution of their work, and shall properly connect and coordinate all work by both the Contractor and other contractors.

If any part of the Contractor's work depends, for proper execution or results, upon the work of any other contractor, the Contractor's responsibility shall be to follow the provisions of Section B-003, under "Conformity with Existing Structures."

3.7 CONFORMITY WITH EXISTING STRUCTURES.

If any part of the Contractor's work depends, for proper execution or results, upon existing work or structures, or upon the work of another contractor, the Contractor shall inspect and promptly report to the Engineer any defects in such work that render it unsuitable for such proper execution and results. The Contractor's failure to so inspect and report shall constitute an acceptance of the existing work or structure as fit and proper for the reception of the Contractor's work, except as to defects that may develop in the existing work or structure after the execution of the Contractor's work.

To insure the proper execution of subsequent work, the Contractor shall measure work already in place and shall at once report to the Engineer any discrepancy between the executed work and the drawings.

3.8 MATERIALS AND EQUIPMENT.

Unless otherwise stipulated in the specifications, all workmanship, equipment, materials, and articles incorporated in the work covered by this Contract are to be new and of the best grade of their respective kinds for the purpose. The Contractor may be required to furnish a statement of the origin, composition, and manufacturer of any or all material proposed for use in the performance of the Contract, together with samples of such materials. The Contractor shall furnish to the Engineer for approval the name of the manufacturer of machinery, mechanical, and other equipment, which the Contractor contemplates installing, together with their performance capacities and other pertinent information.

3.9 STORAGE OF MATERIALS.

Materials shall be so stored as to insure the preservation of their quality and fitness for the work. When considered necessary, they shall be placed on wooden platforms, or other hard, clean surfaces, and not on the ground, and/or they shall be placed under cover. Stored materials shall be located so as to facilitate prompt inspection. Private property shall not be used for storage purposes without the written permission of the owner or lessee.

3.10 MANUFACTURER'S DIRECTIONS.

Manufactured articles, material, and equipment shall be applied, installed, connected, erected, used, cleaned, and conditioned as directed by the manufacturer unless herein specified to the contrary. The Contractor shall, at no cost to the City, arrange for the services of a qualified representative of the equipment manufacturer to inspect the equipment after installation, and to supervise the initial operation for the period of time necessary to insure proper installation and operation.

3.11 SHOP DRAWINGS.

The Contractor shall submit to the Engineer shop drawings for all materials and equipment to be supplied for this project whether stated in the specific sections of the Contract Documents or not. The Contractor shall make any corrections in the drawings required by the Engineer and resubmit same without delay. The Contractor agrees that Shop Drawing submittals processed by the Engineer are not change orders; that the purpose of Shop Drawing submittals by the Contractor is to demonstrate to the Engineer that the Contractor understands the design concept, that the Contractor demonstrates this understanding by indicating which equipment and materials are intended to be furnished and installed, and by detailing the fabrication and installation methods intended for use.

The Contractor further agrees that if deviations, discrepancies, or conflicts between Shop Drawing submittals and the Contract Documents in the form of design Drawings and Specifications are discovered either prior to or after Shop Drawing submittals are processed by the Engineer, the design Drawings and Specifications shall control and shall be followed. Shop Drawings shall be submitted as follows:

- (1) Three (3) copies plus any number desired returned by the Contractor (so at least four (4)) shall be submitted at least thirty (30) days before the materials indicated thereon are to be needed, or earlier if required to prevent delay of the work.
- (2) The Engineer shall, within fourteen (14) days of the submittal of any Shop Drawing, return at least one copy to the Contractor marked with all comments.
- (3) The Contractor shall then correct or revise the Shop Drawings as required to conform to the Contract Documents.
- (4) Following correction or revision, the Contractor shall furnish the Engineer at least four (4) copies of the Shop Drawings conforming to the required corrections and changes.

- (5) The Engineer reserves the right to review corrected or revised Shop Drawings for general compliance with the Contract Documents and to require further corrections or revisions as may be necessary for compliance.

3.12 ORDER OF CONSTRUCTION.

The Engineer shall have control of the order in which various parts of the improvements are to be performed. The Contractor shall submit, at such time as may be requested by the Engineer, schedules which will show the order in which the Contractor proposes to carry on the work, with dates at which the Contractor will start the several parts of the work and estimated dates of completion of the several parts. The order of construction as determined by the Contractor will be followed except where the Engineer determines that such order would not be to the best interests of the City or of the general public.

3.13 PROGRESS.

The Contractor shall at all times maintain a substantial working force to insure completion of the work within the time specified in the Contract. The consistent failure of the Contractor to do so after due warning shall be cause for the City to do the work or to terminate the Contract. See section B-004, under "City's Right To Do Work," and "City's Right To Terminate Contract."

3.14 SUSPENSION OF WORK.

The Engineer shall have authority to suspend the work wholly or in part for such a period or periods of time as may be deemed necessary by the Engineer due to unsuitable weather, unfavorable conditions, or the failure of the Contractor to carry out orders given, or to perform any or all of the provisions of the Contract. The City shall not be liable for expenses incurred by the Contractor during such period of suspension.

3.15 CONSTRUCTION REPORTS.

The Contractor shall submit to the City schedules of costs and quantities of materials, and of other items, which schedules shall be in such form and shall be supported as to the correctness as the City may require for preparing monthly estimates. The Contractor shall also submit to the City the following records: (a) Detailed Estimate, and (b) Periodical Estimates for Partial Payment. These estimates shall be subject to review and correction by the Engineer.

3.16 HOURS OF WORK.

Except for such work as may be required to properly maintain or protect completed or partially completed construction, or to maintain lights and barricades, no work will be permitted on Sundays or legal holidays, nor after six o'clock (6:00) P.M., without specific permission of the Engineer.

3.17 WEATHER.

During freezing or inclement weather, all work shall be suspended except such as can be done in an acceptable manner. The Engineer may permit work to be carried on at such times provided the Engineer approves of the special protection or construction methods proposed. Permission so granted shall in no way be construed as a release of the Contractor's responsibility regarding the quality of the finished work.

3.18 WORKERS AND EQUIPMENT.

The Contractor shall employ competent and efficient workers for every kind of work. Any person employed on the job who shall refuse or neglect to obey the directions of the Engineer or Inspector as relayed through the proper superintendent, or who shall be deemed incompetent or disorderly, or who shall commit trespass upon public or private property in the vicinity of the work, shall be dismissed when the Engineer so orders, and shall not be reemployed unless express permission be given by the Engineer.

3.19 REMOVAL OF UNAUTHORIZED OR DEFECTIVE WORK.

The Contractor shall promptly remove from the premises all materials condemned by the Engineer as failing to conform to the Contract, whether incorporated in the work or not, and the Contractor shall promptly replace and re-execute said work in accordance with the Contract, without expense to the City, and the Contractor shall bear the expense of making good all work of other contractors destroyed or damaged by such removal or replacement. The fact that the Engineer may have previously overlooked such defective work shall not constitute an acceptance of any part of it.

Work done without lines and grades being given, work done beyond lines shown on the plans or as given, except as herein provided, or any extra or additional work done without authority will be considered as unauthorized, at the expense of the Contractor, and will not be paid for under the provisions of the Contract. Work so done may be ordered removed and replaced at the Contractor's expense.

If the Contractor does not remove such condemned work and materials within a reasonable time, fixed by written notice, the City may remove them and may store the material at the expense of the Contractor. If the Contractor does not pay the expense of such removal within ten (10) days time thereafter, the City may, upon ten (10) days written notice, sell such materials at an auction or at a private sale and shall account for the net proceed thereof, after deducting all the costs and expenses that should have been borne by the Contractor.

3.20 CORRECTION OF WORK AFTER FINAL PAYMENT.

Neither the final payment nor any provision in the Contract Documents shall relieve the Contractor of the responsibility for negligence or faulty materials or workmanship within the extent and period provided by law, and upon written notice the Contractor shall remove any defects due thereto, and pay for damage done to other work resulting therefrom, which shall appear within one (1) year(s) after the date of completion and acceptance.

3.21 CLEANING UP.

The Contractor shall at all times keep the premises free from undue accumulations of waste materials or rubbish caused by any work, and shall, as soon after construction as reasonably possible, replace or restore fences, sidewalks, or other property damaged or disturbed by any work. At the completion of the work, the Contractor shall remove all rubbish and waste materials, and all tools, equipment, scaffolding, and surplus materials, and shall leave the premises clean and ready for use, substantially in the same condition as when construction was begun.

Prior to making an application for final payment, the Contractor shall furnish to the Engineer "clean-slips" or affidavits, signed by each property owner abutting the construction site, as determined by the Engineer. This affidavit shall, in each case, attest to the fact that the property has been restored to its original condition, or that the property owner has agreed with the Contractor upon the amount of damages sustained. In the case of a dispute between the property owner and the Contractor, the question shall be referred in writing to the Engineer, who will immediately make an investigation and issue a finding of fact. If the question is not then resolved and the required affidavit obtained from the property owner, the Engineer, upon written application from the Contractor, shall issue a release to the Contractor from the obligation to furnish said affidavit. This dispute may then be settled by other means available to the parties.

In the event that the property owner cannot be located, or does not reply within a reasonable time, then upon receipt of proof that an attempt was made by registered mail to contact said property owner, the Engineer shall issue a release to the Contractor from the obligation to furnish said affidavit.

END OF SECTION B-003

**SECTION B-004 -- LEGAL RELATIONS AND RESPONSIBILITIES
TO THE PUBLIC**

4.1 CONTRACT SECURITY.

The Contractor shall furnish a surety bond (form attached) in an amount of at least one hundred percent (100%) of the contract price as security for the faithful performance of this contract, and as security for the payment of all persons performing labor and furnishing materials in connection with this contract.

4.2 INSURANCE.

The Contractor shall furnish the City Clerk with proper affidavit or affidavits executed by representatives of duly qualified insurance companies, evidencing that said insurance company or companies have issued liability insurance policies, as required below, effective during the life of the contract or for a period of at least ten (10) days following the filling of written notice of cancellation. The work shall not commence under this contract until the Contractor has obtained all insurance required, and such insurance has been approved by the City; nor shall the Contractor allow any Sub-contractor to commence any work until all similar insurance required for the Sub-contractor has been so obtained and approved.

A. COMPENSATION INSURANCE.

The Contractor shall make out and maintain, during the life of this contract, Worker's Compensation Insurance for all employees of the Contractor employed at the site of the work, and in case any work is sublet, the Contractor shall require the Sub-Contractor similarly to provide Worker's Compensation Insurance for all the latter's employees unless such employees are covered by the protection afforded by the Contractor. In case any class of employees engaged in Hazardous Work under this contract at the site of the work is not protected under the Worker's Compensation Statute, the Contractor shall provide, and shall cause each Sub-Contractor to provide, adequate insurance for the protection of all employees not otherwise protected.

B. CONTRACTOR'S LIABILITY INSURANCE.

The Contractor shall maintain Insurance as shall protect the City and the City's employees or agents, the Contractor, and the Sub-contractor performing the work covered by this contract, from claims for damages for personal injury, including accidental death, as well as from claims for property damages which may arise from operations under this Contract, whether such operations be by the Contractor, any Sub-Contractor, or by anyone directly or indirectly employed by either of them.

The minimum protection shall be as follows:

- 1. Public Liability, Bodily Injury, and Property Damage:
 - a. Injury or death of one person \$1,000,000.00
 - b. Injury to more than one person in a single accident \$1,000,000.00
 - c. Property damage \$100,000.00

- 2. Automobile and Truck Public Liability, Bodily Injury, Property Damage:
 - a. Injury or death of one person \$1,000,000.00
 - b. Injury to more than one person in a single accident \$1,000,000.00
 - c. Property damage \$100,000.00

- 3. Excess Liability, Umbrella Form \$3,000,000.00

NOTE: When excavation, trenching, or tunneling is involved, the Property Damage Liability Coverage under the Comprehensive General Liability Policy shall specifically provide coverage for damage to underground property.

All responsibility for maintenance of property and insurance on the work (including but not limited to Builders Risk and Installation Floater) remains solely with the Contractor who may at the Contractor's option insure against any or all perils, and such responsibility shall remain with the Contractor until such time as the work is complete and accepted in writing by the Owner. It is a condition of the Contract that the Owner and Engineer and all Contractors, Subcontractors, and Sub-subcontractors waive all rights of recovery against each other for damages caused by fire or other perils to the extent covered by any valid and collectible insurance, and further, that any policy not including the standard waiver of subrogation clause be so endorsed as to comply with this paragraph.

C. INDEMNITY.

The Contractor shall indemnify and save harmless the City and the City's employees or agents from and against all losses and all claims, demands, payments, suits, actions, recoveries, and judgments of every nature and description brought or recovered against it, by reason of any act or omission of the said Contractor, the Contractor's agents, or employees, in the execution of the work, or in the guarding of it.

4.3 LAWS RELATING TO WORK.

The Contractor is presumed to be familiar with all laws, ordinances, codes, and regulations which may in any manner affect those engaged or employed upon the work, or in the

materials or equipment used in or upon the work, and shall conduct the work so as not to conflict with such laws, ordinances, codes, and regulations.

4.4 PROTECTION OF WORK AND PROPERTY.

The Contractor shall continuously maintain adequate protection of all work from damage and shall protect the City's property from injury or loss arising in connection with this Contract. The Contractor shall provide and maintain all passageways, guard fences, lights, and other facilities for protection required by public authority or local conditions. The Contractor shall provide for referencing and resetting, or for re-establishing, any and all property lines or monuments that are disturbed in the course of the work.

The Contractor shall be held responsible for the care of materials and for partially completed work until final acceptance of same by the City. The Contractor shall correct or make good, at no cost to the City, all damages to adjacent property due to the acts or negligence of any person employed by the Contractor or the prosecution of any work and shall save the City harmless therefrom.

In an emergency affecting the safety of life, the work, or of adjoining property, the Contractor, without special instruction or authorization from the Engineer, is hereby permitted to act in good faith to prevent such threatened loss or injury, and shall do so without appeal if so instructed or authorized. Any compensation, claimed by the Contractor on account of emergency work, shall be determined as provided in Section B-002 of these Contract Documents, entitled "Changes in the Work."

4.5 ACCIDENT PREVENTION AND RESPONSIBILITY FOR ACCIDENT.

Precaution shall be observed by the Contractor at all times for the protection of persons (including employees) and property. The Contractor shall observe the safety provisions of applicable laws, and building and construction codes. Machinery, equipment, and all hazards shall be guarded by the Contractor, or eliminated in accordance with the safety provisions of the Manual of Accident Prevention in Construction, published by the Associated General Contractors of America to the extent that such provision are not in contravention of applicable laws or these Contract Documents. The Contractor shall assume full responsibility for all damages sustained by persons or property due to the carrying on of work, and until final acceptance thereof or until released by the Engineer in writing.

4.6 MAINTENANCE OF BARRICADES AND LIGHTS.

The Contractor shall, at no cost to the City and without further or other order from the City, provide, erect, and maintain at all times during the progress or suspension of the work, and until the completion and final acceptance thereof, suitable and requisite barriers, signs, or other adequate protection as required by the Manual on Uniform Traffic Control Devices,

US DOT, Federal Highway Administration, most current edition, or as may be ordered by the Engineer to ensure the safety of the public. All barricades and obstructions shall be protected at night by signal lights which lights shall be kept burning from sunset to sunrise.

4.7 LANDS FOR WORK.

The City shall provide the lands upon which the work under this Contract is to be done, except that the Contractor shall provide land required for the erection of temporary construction facilities and storage of materials, together with the right of access to same. The Contractor shall confine all equipment, apparatus, the storage of materials, and operations of the workers to limits indicated by laws, ordinances, permits, or directions of the City and shall not unnecessarily encumber the premises with materials.

4.8 SANITARY CONVENIENCES.

The Contractor shall furnish the necessary sanitary conveniences, properly secluded, for the laborers on the site, and these shall be maintained in a manner that will be inoffensive to the public.

4.9 LIENS.

Neither the final payment nor any part of the retained percentage shall become due until the Contractor, if required, shall deliver to the City a complete release of all liens arising out of this Contract, or receipts in full in lieu thereof. If required, an affidavit that so far as the Contractor has knowledge or information the releases and receipts include all the labor and material for which a lien could be filed. If any Sub-contractor refuses to furnish a release or receipt in full, the Contractor may furnish a bond satisfactory to the Engineer, to indemnify the City against any lien. If any lien remains unsatisfied after all payments are made, the Contractor shall refund to the City all moneys that the latter may be compelled to pay in discharging such a lien, including all costs and a reasonable attorney's fee.

4.10 ASSIGNMENT.

The Contractor shall not assign the Contract or sublet it as a whole without the written consent of the City, nor shall the Contractor assign any money due or to become due to them hereunder, without the previous written consent of the Engineer.

4.11 CLAIMS AGAINST CONTRACTOR.

The Contractor shall be held for the payment of all just claims against the Contractor arising out of the prosecution of this Contract, and the Contractor's bonds will not be released until such claims are paid or dismissed.

The City may withhold or, on account of subsequently discovered evidence, nullify the whole or part of any certificate to such extent as may be necessary to protect itself from loss on account of:

- A. Defective work not remedied.
- B. Claims filed or reasonable evidence indicating probable filing of claims.
- C. Failure of the Contractor to make payments properly to Sub-contractors or for material or labor.
- D. A reasonable doubt that the Contract can be completed for the balance then unpaid.
- E. Damage to another Contractor.

When the above grounds are removed, payments shall be made for amounts withheld because of them.

4.12 PERSONAL LIABILITY OF PUBLIC OFFICIALS.

In carrying out any of the provisions of the Contract, or in exercising any power or authority granted thereby, there shall be no liability upon the Engineer or any authorized assistants either personally or as an official of the City, it being understood that in such matters said person acts as the agent and representative of the City.

4.13 NO WAIVER OF LEGAL RIGHTS.

The City shall not be precluded or stopped by any measurement, estimate, or certificate made either before or after the completion and acceptance of the work and payments therefore, from showing the true amount and character of the work performed and materials furnished by the Contractor, or from showing that any such measurement, estimate, or certificate is untrue or incorrectly made, or that the work or materials do not in fact conform to the Contract. The City shall not be precluded or estopped, notwithstanding any such measurement, estimate, or certificate and payment in accordance therewith, from recovering from the Contractor and the Contractor's Surety, such damages as it may sustain by reason of the Contractor's failure to comply with the terms of the Contract. Neither the acceptance by the City of any of its representatives, nor any payment for or acceptance of the whole or any part of the work, nor any extension of time, nor any possession taken by the City, shall operate as a waiver on any portion of the Contract or of any power herein reserved, or any right to damages herein provided. A waiver of any breach of the Contract shall not be held to be a waiver of any other or subsequent breach.

4.14 USE OF COMPLETED PORTIONS.

The City shall have the right to take possession of and use any completed or partially completed portion or portions of the work, but such taking possession and use shall not be

deemed an acceptance of neither the work so used nor any part thereof. If such prior use increases the cost of or delays the work, the Contractor shall be entitled to such extra compensation, or extension of time, or both, as the Engineer may determine.

4.15 MATERIALS FOUND ON THE WORK.

Full right shall vest in the City to any surplus excavated material, unsuitable backfill material, or to any item of value found on the work or in the process of the work. The City reserves the right to order it disposed of at the expense of the Contractor, or removed and stored for the disposition by the City. This provision shall in no way relieve the Contractor of the responsibility of restoration, or of any other provision of these specifications, but is intended, rather, to establish ownership of items and material found on the work.

4.16 CITY'S RIGHT TO DO WORK.

If the Contractor should neglect to prosecute the work properly or fail to perform any provision of this Contract, the City, after three (3) days written notice to the Contractor, may, without prejudice to any other remedy it may have, make good such deficiencies and may deduct the cost thereof from the payment then or thereafter due the Contractor.

4.17 CITY'S RIGHT TO CORRECT DEFICIENCIES.

Upon failure of the Contractor to perform the work in accordance with the Contract Documents, including any requirements with respect to the Schedule of Completion, and after five (5) days written notice to the Contractor, the City may, without prejudice to any other remedy, correct such deficiencies.

4.18 CITY'S RIGHT TO TERMINATE CONTRACT.

The City, upon the certificate of the Engineer that sufficient case exists to justify such action, may, without prejudice to any other right or remedy, and after giving the Contractor seven (7) days written notice, terminate the employment of the Contractor and take possession of the premises and of all materials, tools, and appliances thereon, and finish the work by whatever method it may deem expedient. Action may be taken for any of the following reasons:

- If the Contractor should be judged as bankrupted.
- If the Contractor should make a general assignment for the benefit of any creditors.
- If a receiver should be appointed on account of the Contractor's insolvency.
- If the Contractor should persistently or repeatedly refuse, or should fail, except in cases for which extension of time is provided, to supply enough properly skilled workers or proper materials.

- If the Contractor should fail to make prompt payment to Sub-contractors, or for material or labor, or persistently disregard laws, ordinances codes, or the instructions of the Engineer, or otherwise be guilty of a substantial violation of any provision of the Contract.

In such case, the Contractor shall not be entitled to receive any further payment until the work is finished. If the unpaid balance of the contract price shall exceed the expense of finishing the work, including compensation for additional managerial and administrative services, such excess shall be paid to the Contractor. If such expense shall exceed the unpaid balance, the Contractor shall pay the difference to the City. The Expense incurred by the City as herein provided, and the damage incurred through the Contractor's default, shall be certified by the Engineer.

4.19 CONTRACTOR'S RIGHT TO SUSPEND WORK.

The Contractor may suspend work or terminate the Contract upon seven (7) days written notice to the City and the Engineer, for any of the following reasons:

- If an order of any court, or other public authority, caused the work to be stopped or suspended for a period of ninety (90) days through no act or fault of the Contractor or the Contractor's employees.
- If the Engineer should fail to act upon any Request for Payment within ten (10) days after its presentation in accordance with the General Conditions of this Contract.
- If the City should fail to act upon any Request for Payment within thirty (30) days after its approval by the Engineer.
- If the City should fail to pay the Contractor any sum within thirty (30) days after its award by arbitrators.

4.20 REMOVAL OF EQUIPMENT.

In the case of annulment of the Contract before completion from any cause whatever, the Contractor, if notified to do so by the City, shall promptly remove any part of any equipment and supplies owned by the Contractor from the property of the City, failing which the City shall have the right to remove such equipment and supplies at the expense of the Contractor.

4.21 ENGINEER'S DECISIONS.

The Engineer shall, within a reasonable time after their presentation, make decision in writing on all claims of the City or the Contractor and on all other matters relating to the execution and progress of the work or the interpretation of the Contract Documents.

All such decisions of the Engineer shall be final except in cases where time and/or financial considerations are involved, in which latter case, the decision of the Engineer shall be final and binding on the City and the Contractor unless written objections thereto are delivered to the Engineer by the claimant within twenty (20) days after written notice of such decisions.

END OF SECTION B-004

SECTION B-005 - MEASUREMENT AND PAYMENT

5.1 STANDARDS OF MEASUREMENT.

The quantities of work performed will be computed by the Engineer on the basis of measurements taken by the Engineer or any assistants according to the United States Standard Measurements and Weights. A Minimum of two working days notice shall be given to the owner so that the owner can mark limits of material for the contractor to follow.

5.2 USE OF CITY WATER.

The Contractor will be allowed to use City water, but before any water is used, the Contractor shall make an application to the Engineer who will provide and install suitable meters and supply the Contract representative with suitable hydrant wrenches when the use of hydrants is necessary. The Contractor shall designate one employee who shall be responsible for operating the hydrants used by the Contractor. The employee so designated shall be under the direct supervision of the Engineer and no other employee may operate any hydrant or valve without the written permission of the Engineer. The meters shall not be moved by the Contractor, but will be moved by City Employees as directed by the Contractor. The water used will be charged to the Contractor at the rate of zero dollars (\$ 0.00) per 1,000 gallons.

5.3 CLAIMS FOR EXTRA COST.

If the contractor claims that any new instructions by drawings or otherwise, after the Contract has been signed, involve extra cost under this Contract, the Contractor shall give the Engineer written notice thereof within seven (7) calendar days after receipt of such instructions, and in any event before proceeding to execute the work, except in an emergency endangering life or property, and the procedure shall then be as provided for in Section B-002 of the Contract Documents under "Changes in the Work."

5.4 BASIS FOR PAYMENT.

Progress payment and final payment shall be made in conformity with the Proposal, which is attached hereto and made a part of the Contract. Limits of measurement for each item shall be outlined in the applicable section of the Specifications.

5.5 DEDUCTIONS FOR UNCORRECTED WORK.

If the Engineer deems it inexpedient to correct work injured or done in accordance with the Contract, an equitable deduction from the Contract Price shall be made therefore.

5.6 TAXES.

A. SALES TAX.

The City of Grinnell is a designed exempt entity. Designated exempt entities awarding construction contracts on or after January 1, 2003, may issue special exemption certificates to contractors and subcontractors allowing them to purchase or to withdraw from inventory construction materials for the contract free from sales tax.

The City of Grinnell is hereby notifying all potential bidders to submit their bids WITHOUT sales tax included. This policy will lower the dollar amount of the bid and the Contractor will not be required to provide Contractor Statements after the project is completed. The following steps will be used to complete this process:

1. Designated exempt entities will register contracts, including information on contractors and subcontractors, through an online application developed by the Iowa Department of Revenue.
2. Designated exempt entities will provide each contractor/subcontractor with an exemption certificate/authorization letter developed exclusively for this purpose. These will be printed directly from the online application. The letter/certificate can be obtained only through this application.
3. Contractors and subcontractors will give a copy of the certificate to each of their material suppliers. This allows them to purchase building materials for the contract free from sales tax.
4. Suppliers should retain this certificate in their records for at least three years.

B. OTHER TAXES.

The Contractor shall pay all taxes involved in the completion of the work under the Contract except the sales tax on the construction materials mentioned above, shall pay all Social Security and unemployment taxes, and is responsible for withholding taxes and any other state or federal requirements in this regard.

C. OUT-OF-STATE CONTRACTORS.

All out-of-state contractors shall meet all Iowa laws and regulations relating to out-of-state contractors.

END OF SECTION B-005

SECTION B-006 -- TIME OF COMPLETION

6.1 EXTENSIONS OF TIME.

All time limits stated in the Contract Documents are of the essence of the Contract. Upon receipt of written notice from the Contractor of the existence of causes over which said Contractor has no control and which must delay the completion of the work, the Engineer may, at the Engineer's discretion, extend the date specified for the completion of the work. No allowance will be made to the Contractor for stoppage or suspension of the work by the Engineer, unless stoppage or suspension is due to the fault of the City, then extension of time corresponding to the duration of stoppage or suspension will be allowed for the completion of the work.

END OF SECTION B-006

DIVISION C

TECHNICAL PROVISIONS

SUBDIVISION C.1

BITUMINOUS SEAL COAT

SECTION C.1-001 – GENERAL SPECIFICATIONS

1. SCOPE OF WORK.

The work contemplated herein involves the preparation of roadbed to receive the placement of seal coat, and the laying of seal coat on the streets.

2. CITY SUPPLIED MATERIALS.

The City will not supply any material nor perform any of the work contemplated under this contract.

3. PROTECTION OF LAWNS AND TREES.

The contractor shall make special efforts to reduce damage to lawns and trees, and where damage is accidentally caused, shall restore/replace the lawns and/or trees in an acceptable manner. Where the use of private property is convenient to the Contractor, the Contractor shall make any necessary arrangements with such private owners.

4. WORK WITHIN STATE HIGHWAY AND RAIROAD RIGHTS-OF-WAY.

All work performed by and all operations of the Contractor, including all employees and Subcontractors under the Contractor, within the limits of highway and railroad rights-of-way shall be in conformity with the requirements of, and be under control of (through the City), the highway or railroad authority owning, or having jurisdiction over and control of, such right-of-way in each case.

END OF SECTION C.1-001

SECTION C.1-002 – TECHNICAL SPECIFICATIONS

1. PREPERATION FOR AND APPLICATION OF BITUMINOUS SEAL COAT.

The contractor shall prepare the streets and place the bituminous seal coat as per the requirements and specifications in Section 2307 “Standard Specifications for Highway and Bridge Construction”, Iowa Department of Transportation, Series 2001.

2. RECORDS.

The Contractor shall keep a record in a field book or on a separate record set of plans indicating by station the actual location each load of aggregate and bituminous materials is laid. Such field notes shall be available to the City for the preparation of as-built plans.

3. CLEAN-UP.

Areas disturbed shall be restored to those conditions, which existed prior to construction, unless otherwise noted on the plans or instructed, by the Engineer.

Roadways shall be prepared, seeded or sodded, and fertilized in compliance with the Standard Specifications for Highway and Bridge Construction, Iowa Department of Transportation.

Shrubbery, trees, or flowers, which have been damaged by the construction, shall be replaced with new plantings of equal type and quality to that which was damaged.

At all times, the site shall be kept free from accumulations of waste materials and rubbish caused by the work, and upon completion of the work, all rubbish, tools, scaffolding, forms, and surplus materials shall be removed.

The Contractor shall be responsible, financially and otherwise, for the refilling and repair of all settlement and the repair or replacement to the original or better condition of all pavement, top surfaces, driveways, areaways, curbs, gutters, walks, surface structures, utilities, drainage facilities, sod, and shrubbery which have been damaged as a result of said replacement operations. The Contractor shall make, or cause to make, all necessary replacements, and repairs or replacements appurtenant thereto, within thirty (30) days from and after due notification by the Engineer or City of settlement and resulting damage at any designated location or locations.

4. BASIS OF PAYMENT.

The Contractor will be paid the square yard contract price which shall include all materials and labor necessary to meet the contract specifications. Payment will be based on actual quantities after work has been completed and accepted.

5. PROTECTION OF WORK.

The Contractor is responsible for protecting all work during construction, and shall employ all means to protect the public from harm.

6. Warranty Period

The contractor will be responsible for correcting any areas where bleeding of the asphalt binder appears for the 2026 season.

7. Application of Bituminous

The contractor shall not be allowed to apply bituminous material to any areas within two days of a rain event without approval from the City of Grinnell representative.

8. Parking on Work Areas

The contractor shall be responsible for posting no parking notifications not less than twenty four (24) hours in advance for areas where parking is normally permitted.

END OF SECTION C.1-002

SECTION C.1-003 – MATERIAL SPECIFICATIONS

1. AGGRGATE.

The aggregate used for this project shall be 3/8”, washed and free from objectionable clay coatings. The aggregate shall be dry at the time of application. The gradation shall be as follows:

	SIEVE SIZE					
	1/2	3/8	4	8	30	200
% Passing	100	90-100	10-55	0-20	0-7	0-1.5

Aggregate shall be spread at a rate of twenty to twenty-five (25) pounds per square yard. The rate of application shall be inspected and modified if necessary by a representative of the City of Grinnell during the time of application.

2. BITUMINOUS MATERIAL.

The Bituminous material shall be MC 3000, and meet the requirements in Sections 2307 and 4140.01, “Standard Specifications for Highway and Bridge Construction”, Iowa Department of Transportation, Series 2001.

The MC3000 shall be applied at a rate of 0.32 gallons per square yard for single coat chip seal. The MC3000 shall be applied at a rate of 0.25 gallons per square yard the first pass and 0.30 gallons per square yard for the second pass on double chip seal streets.

3. ROLLING OF AGGREGATE.

Immediately after the aggregate has been placed a team of rubber tired rollers shall roll the aggregate. A total of eight-roller coverage at a speed of no more than five (5) miles per hour shall occur over the entire street surface in order to firmly embed the aggregate in the binder. Care shall be taken to not have the rubber-tired rollers start and stop suddenly. Any scuffs in the seal coat shall be promptly repaired prior to moving to the next street section.

END OF SECTION C.1-003

RESOLUTION NO. 2026-27

A RESOLUTION APPROVING CONTRACT CHANGE ORDER NO. 4 IN THE AMOUNT OF \$8,817.42 FOR A NET INCREASE TO THE CONTRACT WITH WRH, INC. FOR THE WATER TREATMENT PLANT PROJECT.

WHEREAS, the City of Grinnell did enter into a contract with WRH, Inc. on December 2, 2024, for the Water Treatment Plant Project; and

WHEREAS, WRH, Inc. has submitted Contract Change Order No. 4 for a net increase in the contract of \$8,817.42; and

WHEREAS, the Project Engineer has reviewed the change order and recommends approval of Contract Change Order No. 4; and

NOW, THEREFORE, BE IT RESOLVED, by the City Council of Grinnell, Iowa, in regular session this 16th day of March 2026 that the contract amount has increased by \$8,817.42 in accordance with Contract Change Order No. 4 is hereby approved as executed.

Passed and approved this 16th day of March 2026.

Sam Cox, Mayor

Attest:

Erienne Doll, Deputy City Clerk



CONTRACT CHANGE ORDER

	CONTRACT CHANGE ORDER	Change Order Number:	004
		MEC Project Number:	2022000116-003
		Contract Date:	12/2/2024
For Contracted Project:	Water System Improvements 2023 Water Treatment Plant	Date of Issuance:	3/5/2026
		Effective Date:	
		Original Contract Price:	\$ 18,990,000.00
Owner:	City of Grinnell	Current Contract Price:	\$ 19,110,273.17
Contractor:	WRH, Inc.	Current Contingency Allowance:	\$ -
		Current Substantial Completion Date:	1/20/2027

You are hereby requested to comply with the following changes below from the original contracted plans and specifications.

Description of Changes	ADJUSTMENT to Substantial Completion Date	DECREASE in Contract Price	INCREASE in Contract Price
1. CAR-16 Water Service Valve	4	\$ -	\$ 4,811.20
2. CAR-17 Sanitary Service Piping Materials	2	\$ -	\$ 4,006.22
	-	\$ -	\$ -
	-	\$ -	\$ -
	-	\$ -	\$ -
	-	\$ -	\$ -
	-	\$ -	\$ -
	-	\$ -	\$ -
	-	\$ -	\$ -
Totals:	6	\$ -	\$ 8,817.42
Updated Substantial Completion Date:	1/26/2027		
Net Change to Contract Price:		\$	8,817.42
Updated Contract Price:		\$	19,119,090.59

Justification: See attached PCO Breakdown.

The Amount of the Contingency Allowance will be UNCHANGED by the Sum of:	N/A
<i>Zero and 00/100 Dollars</i>	
The Total Remaining Contingency Allowance including this and previous Change Orders will be:	N/A
<i>Zero and 00/100 Dollars</i>	
The Amount of the Contract will be INCREASED by the Sum of:	\$8,817.42
<i>Eight Thousand, Eight Hundred Seventeen and 42/100 Dollars</i>	
The Total Contract Price including this and previous Change Orders will be:	\$19,119,090.59
<i>Nineteen Million, One Hundred Nineteen Thousand, Ninety and 59/100 Dollars</i>	
The Contract Period provided for Substantial Completion will be INCREASED to:	1/26/2027

This Document will become a Supplement to the Contract dated 12/02/2024, and all Provisions will apply hereto.

Requested By:	Contractor: WRH, Inc.	Date
Recommended By:	Engineer: McClure Engineering Co.	3/5/2026
Accepted By:	Owner: City of Grinnell	3/5/2026
Approved by Funding Agency: (if applicable)		Date

This information will be used as a record of any changes to the Original Construction Contract.



Change Authorization Request

BUILD TODAY FOR A BETTER TOMORROW

Water System Improvement 2023 Water Treatment Plant Grinnell, Iowa

Date: March 4, 2026

16

6" water connection detail indicating additional material needed for the service. Please advise

	Quantity	Unit	Unit Rate	Line Total
Subcontractors				
				\$ -
				\$ -
				\$ -
				\$ -
			SUBTOTAL	\$ -

Labor				
	Quantity	Unit	Unit Rate	Line Total
Project Manager	1.0	mhr	\$ 184.36	\$ 184.36
Asistant Project Manager	0.0	mhr	\$ 90.96	\$ -
Safety Professional	0.0	mhr	\$ 94.33	\$ -
Superintendent - ST	1.0	mhr	\$ 104.76	\$ 104.76
Superintendent - OT	0.0	mhr	\$ 157.14	\$ -
Foreman - ST	0.0	mhr	\$ 98.96	\$ -
Foreman - OT	0.0	mhr	\$ 148.44	\$ -
Carpenter - ST	0.0	mhr	\$ 98.96	\$ -
Carpenter - OT	0.0	mhr	\$ 148.45	\$ -
Operator (A) - ST	0.0	mhr	\$ 98.50	\$ -
Operator (A) - OT	0.0	mhr	\$ 147.75	\$ -
Operator (B) - ST	0.0	mhr	\$ 92.48	\$ -
Operator (B) - OT	0.0	mhr	\$ 138.72	\$ -
Laborer - ST	0.0	mhr	\$ 92.78	\$ -
Laborer - OT	0.0	mhr	\$ 139.17	\$ -
ATV Driver - ST	0.0	mhr	\$ 92.48	\$ -
ATV Driver - OT	0.0	mhr	\$ 138.72	\$ -
Truck Driver - ST	0.0	mhr	\$ 92.48	\$ -
Truck Driver - OT	0.0	mhr	\$ 138.72	\$ -
			SUBTOTAL	\$ 289.12

Equipment (without operator)				
	Quantity	Unit	Unit Rate	Line Total
General Conditions		day	\$2,224.60	\$0.00
Wendler Winter Conditions		day	\$2,000.00	\$0.00
Skidloader - Tracked/Rubber Tire		Hr	\$55.47	\$0.00
End loader - Rubber Tire		Hr	\$117.88	\$0.00
Telehandler		Hr	\$76.27	\$0.00
Excavator - Mini		Hr	\$62.41	\$0.00



Change Authorization Request

**BUILD TODAY FOR
A BETTER TOMORROW**

Excavator - 34,000 LB	Hr	\$97.08	\$0.00
Excavator - 68,000 LB	Hr	\$194.15	\$0.00
Vacuum Excavator - Trailer	Hr	\$97.08	\$0.00
Vacuum Excavator - Truck	Hr	\$277.37	\$0.00
110 Crawler Crane	Hr	\$343.23	\$0.00
Dozer	Hr	\$124.81	\$0.00
Water Pump	Hr	\$49.00	\$0.00
Compactor	Hr	\$55.47	\$0.00
Ground Heater	Hr	\$13.87	\$0.00
GPS Base/Rover/ Machine Control	Hr	\$76.27	\$0.00
Truck	Hr	\$14.00	\$0.00
Flatbed Truck	Hr	\$69.34	\$0.00
Boom Truck	Hr	\$173.35	\$0.00
Pump Truck	Hr	\$362.56	\$0.00
Dump Truck	Hr	\$80.00	\$0.00
Semi & Trailer	Mi	\$3.47	\$0.00
<i>SUBTOTAL</i>			<i>\$0.00</i>

Material

Core & Main	1	LS	\$ 3,812.50	\$	3,812.50
			\$ -	\$	-
			\$ -	\$	-
				\$	-
<i>SUBTOTAL</i>			<i>\$</i>		<i>3,812.50</i>

C.A.R. SUBTOTAL \$ ***4,101.62***

Overhead, Subcontractors	5.00%	\$	-
Overhead, Self-Performed	15.00%	\$	615.24

\$ 4,716.86

Bond 2.00% \$ 94.34

Total Proposed Change \$ **4,811.20**

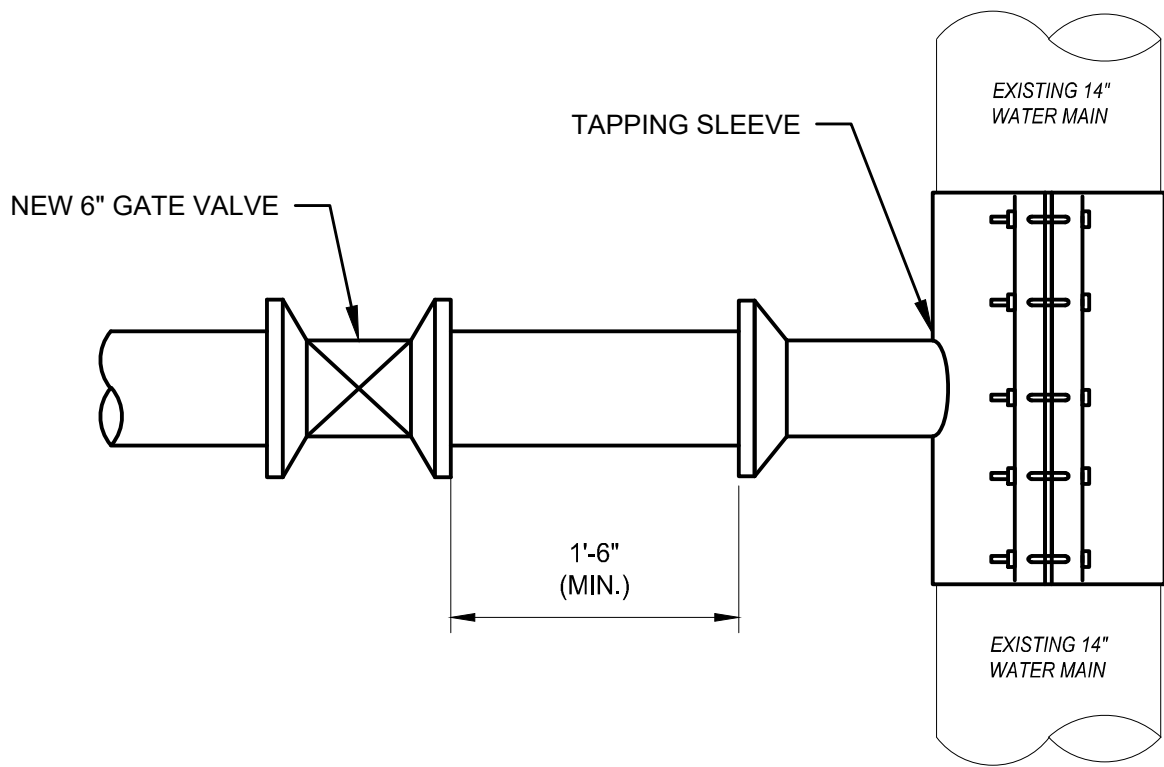
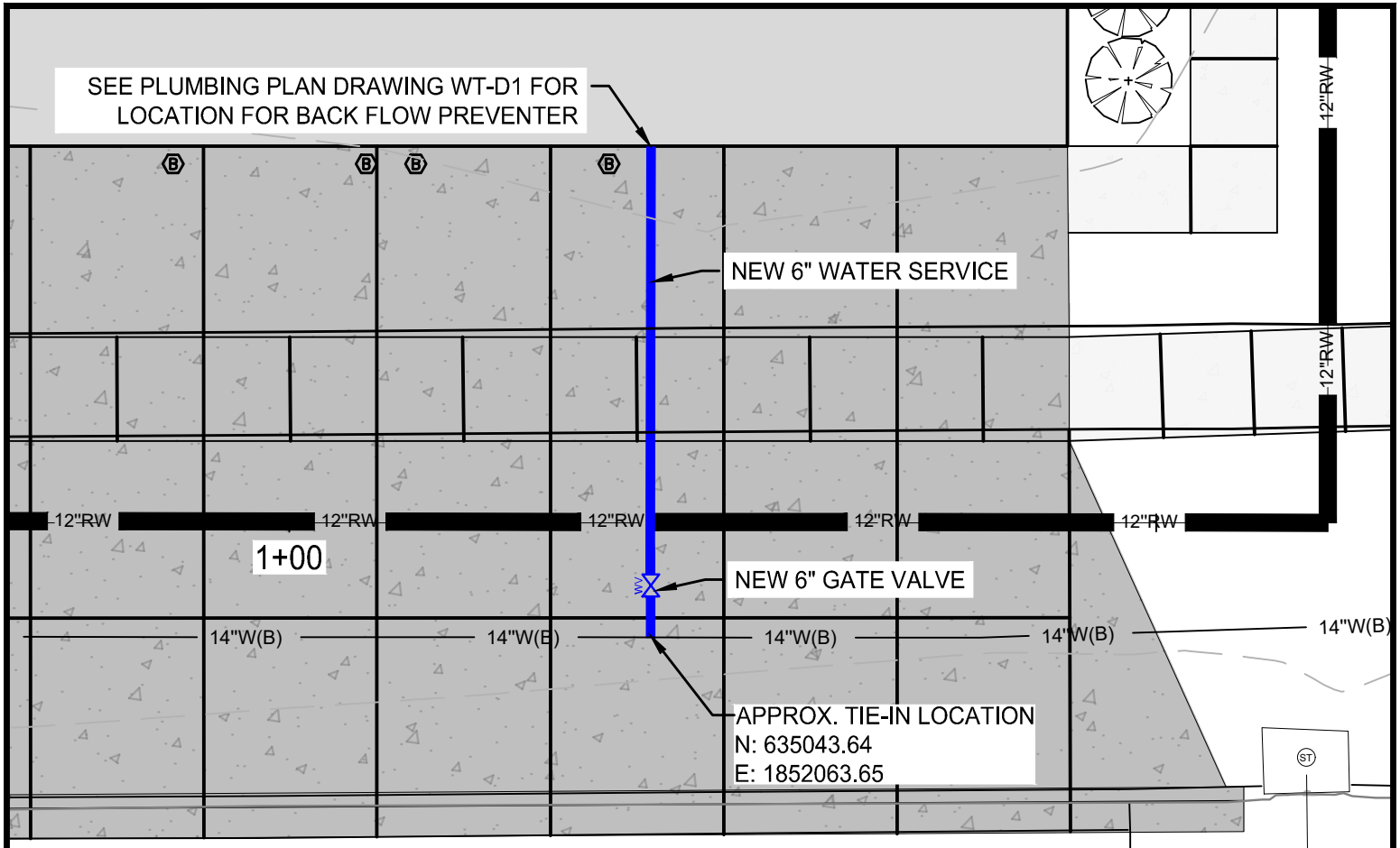

GENERAL NOTE:
 MAINTAIN MIN. 5-FT DEPTH TO TOP OF 6" WATER SERVICE

6" WATER SERVICE CONNECTION DETAIL



Bid Proposal for Copy of GRINNELL WTP TAPPING SLEEVE

WENDLER INC

Job Location: GRINNELL, IA
Bid Date: 02/25/2026 08:00 am
Core & Main Bid #: 4777085

Core & Main
 2500 SE Enterprise Dr
 Grimes, IA 50111
Phone: 5159864000
Fax: 5159864400

Seq#	Qty	Description	Units	Price	Ext Price
THIS PROJECT IS BEING BID IN ACCORDANCE WITH AIS REQUIREMENTS.					
TAPPING SLEEVE					
10					
20	1	665-153006MJ-000 14X6 SS TAP SLV 304SS MJ OUTLET 15.30-15.80 OD	EA	1,600.00	1,600.00
30	1	TAPPING SERVICES	EA	750.00	750.00
40	1	6 MJ RW GATE VLV OL	EA	1,095.00	1,095.00
50	1	664-S VLV BOX W/LID DOM 26T, 36B, WATER DROP IN LID	EA	275.00	275.00
60	0	#60 SCREW VLV BOX 24" EXT USA THRD DOMESTIC EXTENSION ONLY	EA	95.00	0.00
70	1	VBAll-A VALVE BOX ADAPTOR FITS 3"-8" AFC 2", 2-1/2", 3" MUELLER 3" KENNEDY CLOW M&H	EA	60.00	60.00
80	1	6 STAR 3006 DIP REST SB AIS USA STARBOND L/ACC SGDPS06RDD	EA	32.50	32.50
90	0	6 STAR 4006 PVC REST SB AIS USA STARBOND L/ACC PVCS4006G2DD	EA	42.00	0.00
PLEASE NOTE					
120					
130					
140					
150					
160					
170					
180					
190					
200					
210					
220					
230					
240					
				Sub Total	3,812.50
				Tax	0.00
				Total	3,812.50

UNLESS OTHERWISE SPECIFIED HEREIN, PRICES QUOTED ARE VALID IF ACCEPTED BY CUSTOMER AND PRODUCTS ARE RELEASED BY CUSTOMER FOR MANUFACTURE WITHIN THIRTY (30) CALENDAR DAYS FROM THE DATE OF THIS QUOTATION. CORE & MAIN LP RESERVES THE RIGHT TO INCREASE PRICES TO ADDRESS FACTORS, INCLUDING BUT NOT LIMITED TO, GOVERNMENT REGULATIONS, TARIFFS, TRANSPORTATION, FUEL AND RAW MATERIAL COSTS. DELIVERY WILL COMMENCE BASED UPON MANUFACTURER LEAD TIMES. ANY MATERIAL DELIVERIES DELAYED BEYOND MANUFACTURER LEAD TIMES MAY BE SUBJECT TO PRICE INCREASES AND/OR APPLICABLE STORAGE FEES. THIS BID PROPOSAL IS CONTINGENT UPON BUYER'S ACCEPTANCE OF SELLER'S TERMS AND CONDITIONS OF SALE, AS MODIFIED FROM TIME TO TIME, WHICH CAN BE FOUND AT: <https://coreandmain.com/terms-of-sale/>

THIS BID MAY INCLUDE GLOBALLY SOURCED (IMPORTED) MATERIALS THAT ARE SUBJECT TO CHANGING TARIFFS. PRICES ARE SUBJECT TO CHANGE DUE TO POTENTIAL ADDITIONAL TARIFFS IMPOSED BY THE U.S. GOVERNMENT. IF IMPOSED, PRICES WILL INCREASE BY THE SAME PERCENTAGE AND WILL BE EFFECTIVE ON THE DATE THAT THE NEW TARIFFS ARE IMPLEMENTED. THESE ITEMS SHOULD BE PURCHASED WITH HASTE TO AVOID ANY ADDITIONAL RISING TARIFF COSTS.

Actual taxes may vary



Change Authorization Request

**BUILD TODAY FOR
A BETTER TOMORROW**

Water System Improvement 2023 Water Treatment Plant Grinnell, Iowa

Date: March 4, 2026

17

6" sanitary sewer additional material & time needed for the service. Please advise

	Quantity	Unit	Unit Rate	Line Total
Subcontractors				
				\$ -
				\$ -
				\$ -
				\$ -
			SUBTOTAL	\$ -

Labor				
	Quantity	Unit	Unit Rate	Line Total
Project Manager	1.0	mhr	\$ 184.36	\$ 184.36
Asistant Project Manager	0.0	mhr	\$ 90.96	\$ -
Safety Professional	0.0	mhr	\$ 94.33	\$ -
Superintendent - ST	1.0	mhr	\$ 104.76	\$ 104.76
Superintendent - OT	0.0	mhr	\$ 157.14	\$ -
Foreman - ST	0.0	mhr	\$ 98.96	\$ -
Foreman - OT	0.0	mhr	\$ 148.44	\$ -
Carpenter - ST	0.0	mhr	\$ 98.96	\$ -
Carpenter - OT	0.0	mhr	\$ 148.45	\$ -
Operator (A) - ST	4.0	mhr	\$ 98.50	\$ 394.00
Operator (A) - OT	0.0	mhr	\$ 147.75	\$ -
Operator (B) - ST	0.0	mhr	\$ 92.48	\$ -
Operator (B) - OT	0.0	mhr	\$ 138.72	\$ -
Laborer - ST	8.0	mhr	\$ 92.78	\$ 742.24
Laborer - OT	0.0	mhr	\$ 139.17	\$ -
ATV Driver - ST	0.0	mhr	\$ 92.48	\$ -
ATV Driver - OT	0.0	mhr	\$ 138.72	\$ -
Truck Driver - ST	0.0	mhr	\$ 92.48	\$ -
Truck Driver - OT	0.0	mhr	\$ 138.72	\$ -
			SUBTOTAL	\$ 1,425.36

Equipment (without operator)			
	Quantity	Unit Rate	Line Total
General Conditions	day	\$2,224.60	\$0.00
Wendler Winter Conditions	day	\$2,000.00	\$0.00
Skidloader - Tracked/Rubber Tire	Hr	\$55.47	\$0.00
End loader - Rubber Tire	Hr	\$117.88	\$0.00
Telehandler	Hr	\$76.27	\$0.00
Excavator - Mini	Hr	\$62.41	\$0.00



Change Authorization Request

**BUILD TODAY FOR
A BETTER TOMORROW**

Excavator - 34,000 LB	Hr	\$97.08	\$0.00
Excavator - 68,000 LB	Hr	\$194.15	\$0.00
Vacuum Excavator - Trailer	Hr	\$97.08	\$0.00
Vacuum Excavator - Truck	Hr	\$277.37	\$0.00
110 Crawler Crane	Hr	\$343.23	\$0.00
Dozer	Hr	\$124.81	\$0.00
Water Pump	Hr	\$49.00	\$0.00
Compactor	Hr	\$55.47	\$0.00
Ground Heater	Hr	\$13.87	\$0.00
GPS Base/Rover/ Machine Control	Hr	\$76.27	\$0.00
Truck	Hr	\$14.00	\$0.00
Flatbed Truck	Hr	\$69.34	\$0.00
Boom Truck	Hr	\$173.35	\$0.00
Pump Truck	Hr	\$362.56	\$0.00
Dump Truck	Hr	\$80.00	\$0.00
Semi & Trailer	Mi	\$3.47	\$0.00
SUBTOTAL			\$0.00

Material

Core & Main	1	LS	\$ 1,990.00	\$ 1,990.00
			\$ -	\$ -
			\$ -	\$ -
			\$ -	\$ -
SUBTOTAL			\$ 1,990.00	

C.A.R. SUBTOTAL \$ 3,415.36

Overhead, Subcontractors	5.00%	\$ -
Overhead, Self-Performed	15.00%	\$ 512.30

\$ 3,927.66

Bond 2.00% \$ 78.55

Total Proposed Change \$ 4,006.22



Bid Proposal for GRINNELL SANITARY C900

WENDLER INC

Job Location: GRINNELL, IA
Bid Date: 03/04/2026 08:00 am
Core & Main Bid #: 4778137

Core & Main
 2500 SE Enterprise Dr
 Grimes, IA 50111
Phone: 5159864000
Fax: 5159864400

Seq#	Qty	Description	Units	Price	Ext Price
THIS PROJECT IS BEING BID IN ACCORDANCE WITH AIS REQUIREMENTS.					
10		C900			
20	100	6 PVC C900 DR18 PIPE 20' GSKT PC235	FT	9.75	975.00
40	1	6 MJ L/P SLV C153 USA	EA	245.00	245.00
50	2	6 MJ 45 C153 USA	EA	245.00	490.00
60	1	6 MJXIPS PVC TRANS GASKET	EA	10.00	10.00
70	6	6 STAR 4006 PVC REST SB AIS USA STARBOND L/ACC PVCS4006G2DD	EA	45.00	270.00
100		PLEASE NOTE			
110		ALL MJ FITTINGS AND VALVES ARE			
120		QUOTED WITH COR-BLUE T-BOLTS			
130		AND NUTS. THANK YOU!			
				Sub Total	1,990.00
				Tax	0.00
				Total	1,990.00

UNLESS OTHERWISE SPECIFIED HEREIN, PRICES QUOTED ARE VALID IF ACCEPTED BY CUSTOMER AND PRODUCTS ARE RELEASED BY CUSTOMER FOR MANUFACTURE WITHIN THIRTY (30) CALENDAR DAYS FROM THE DATE OF THIS QUOTATION. CORE & MAIN LP RESERVES THE RIGHT TO INCREASE PRICES TO ADDRESS FACTORS, INCLUDING BUT NOT LIMITED TO, GOVERNMENT REGULATIONS, TARIFFS, TRANSPORTATION, FUEL AND RAW MATERIAL COSTS. DELIVERY WILL COMMENCE BASED UPON MANUFACTURER LEAD TIMES. ANY MATERIAL DELIVERIES DELAYED BEYOND MANUFACTURER LEAD TIMES MAY BE SUBJECT TO PRICE INCREASES AND/OR APPLICABLE STORAGE FEES. THIS BID PROPOSAL IS CONTINGENT UPON BUYER'S ACCEPTANCE OF SELLER'S TERMS AND CONDITIONS OF SALE, AS MODIFIED FROM TIME TO TIME, WHICH CAN BE FOUND AT: <https://coreandmain.com/terms-of-sale/>

THIS BID MAY INCLUDE GLOBALLY SOURCED (IMPORTED) MATERIALS THAT ARE SUBJECT TO CHANGING TARIFFS. PRICES ARE SUBJECT TO CHANGE DUE TO POTENTIAL ADDITIONAL TARIFFS IMPOSED BY THE U.S. GOVERNMENT. IF IMPOSED, PRICES WILL INCREASE BY THE SAME PERCENTAGE AND WILL BE EFFECTIVE ON THE DATE THAT THE NEW TARIFFS ARE IMPLEMENTED. THESE ITEMS SHOULD BE PURCHASED WITH HASTE TO AVOID ANY ADDITIONAL RISING TARIFF COSTS.

	REQUEST FOR INFORMATION	RFI Number:	050
		MEC Project Number:	2022000116-003
For Contracted Project:	Water System Improvements 2023 Water Treatment Plant	Date Submitted:	2/20/2026
		Date Responded:	2/25/2026
		RFI Requested by: WRH, Inc.	
Owner:	City of Grinnell, Iowa	RFI Subject:	
Contractor:	WRH, Inc.	Facility Sanitary Sewer Piping	

Drawing / Sheet Number:	WT-C6, WT-C12	Detail Number:		Specification Section:	
-------------------------	---------------	----------------	--	------------------------	--

Request: (Include Proposed Solution If Appropriate)
 See attached.

Action Required By:	Engineer		Date Response Required:	2/25/2026
----------------------------	----------	--	--------------------------------	-----------

Response:
 Install sanitary sewer in compliance with Iowa DNR Water Main and Sewer Separation Requirements.
 Please send a change proposal for the change in materials related to the work referenced in this RFI.

Response Prepared By:	Trent Wilson, P.E.		Attachments:	Yes
------------------------------	--------------------	--	---------------------	-----

Distribution List: Procure Project: 2402-00-1445 1445-Grinnell WTP Improvements 2023
 File



Wendler Inc.
 415 12th Ave SE
 Cedar Rapids, Iowa 52401
 P: (319) 622-3816

Project: 1445 GRINNELL WTP IMPROVEMENTS

2023
 703 Broad St
 Grinnell, Iowa 50112

RFI #50: Proposed Sanitary Sewer Service

Revision	0	Status	Open
To	Corey Falzone (McClure Engineering Co.) Jen Collens (McClure Engineering Co.) Trent Wilson (McClure Engineering Co.)	From	Colton Singbeil (Wendler Inc.) 415 12th Ave SE Cedar Rapids, Iowa 52401
Date Initiated	Feb 20, 2026	Due Date	Feb 25, 2026
Location	Grinnell Water Treatment Plant	Project Stage	
Cost Impact	Yes (Unknown)	Schedule Impact	Yes (Unknown)
Spec Section		Cost Code	
Drawing Number	WT-C6, WT-C12	Reference	
Linked Drawings			
Received From	Derek Hutchinson (Wendler Inc.)	Sub Job	
Copies To	Derek Hutchinson (Wendler Inc.), Bud Maynard (Wendler Inc.), Joe Smith (Wendler Inc.), Brad Walker (Wendler Inc.)		

Activity

Question

Question from Colton Singbeil Wendler Inc. on Friday, Feb 20, 2026 at 12:58 PM CST

Wendler has uncovered the existing 14" water main running along 2nd Ave. The proposed elevation shown on Sheet WT-C12 indicates an elevation of 1012.00 at the bottom of pipe; however, field verification has confirmed the actual elevation is 1010.00.

In order to install the proposed sanitary sewer beneath the existing water main and maintain the required 18" vertical clearance, adjustments to the proposed sanitary alignment and/or profile will be necessary. Additionally, the proposed sanitary line shown on WT-C12 is within the required 10' horizontal separation (north to south direction) from the water main.

Modifications will be required. These revisions constitute a change in the existing scope of work.

Please advise on how you would like to proceed.

Awaiting an Official Response



May 2024

Water Supply Engineering Section

Tara Naber, PE | 515-776-8922 | tara.naber@dnr.iowa.gov

Water Main and Sewer Separation Requirements FAQ

Background on 2022 Changes

Updates to 567 IAC 43.3 (2)"a"(3) to replace subparagraph (3) with new subparagraphs (3) and (4) were made to allow for added flexibility for water main project design with regards to separation from sanitary and storm sewers effective March 16, 2022. Previously, water main separation from sewers was covered by Chapter 12 of the Wastewater Engineering Design Standards, which were written based on sewer construction rather than water main construction. The previous requirements did not account for conflicts with existing sewer infrastructure and treated sanitary sewers and storm sewers equally. The updates to 567 IAC 43.3(2)"a"(3) state the requirements for separation based on water main construction and provide common alternatives that were previously allowed through the waiver process. The following tables outline the requirements and options for handling separation conflicts between a water main and sewer based on the updated rule.

Separation of Water Mains and Sanitary Sewers

Horizontal Separation: Gravity Sanitary and Combined Sewers

Scenario	Requirements
Separation \geq 10 feet, edge to edge	No additional requirements
3 feet \leq separation < 10 feet, edge to edge, with water main located at least 18 inches above top of sewer	The water main must be placed in a separate trench or on a bench of undisturbed earth in the same trench as the sewer.
3 feet \leq separation < 10 feet, edge to edge, with water main located less than 18 inches above top of sewer	Option 1: construct water main within watertight casing pipe with evenly spaced annular gap and watertight end seals, or Option 2: construct sewer of water main materials.
If it is not possible to obtain 3 feet \leq separation < 10 feet, edge to edge, with water main located less than 18 inches above top of sewer; and if there is 2 feet \leq separation < 3 feet, edge to edge	Option 1: The water main shall be enclosed in watertight casing pipe with an evenly spaced annular gap and watertight end seals, or Option 2: Sewer must be constructed of water main materials
Separation < 2 feet	Not allowed

Horizontal Separation: Sanitary Sewer Force Mains

Scenario	Requirements
Separation \geq 10 feet, edge to edge	No additional requirements
4 feet \leq separation < 10 feet, edge to edge	Sewer must be constructed of water main materials
Separation < 4 feet	Not allowed

Vertical Separation / Crossings: Gravity Sanitary and Combined Sewers

Scenario	Requirements
Separation \geq 18 inches, water main located above sewer	No additional requirements
6 inches \leq separation < 18 inches, water main located above sewer	Option 1: construct water main within watertight casing pipe with evenly spaced annular gap and watertight end seals, or
Separation \geq 18 inches, water main located below sewer	Option 2: construct sewer of water main materials
Separation < 6 inches, water main above sewer	Not allowed
Separation < 18 inches, water main below sewer	

Manholes: Water main must have 3 feet of horizontal separation from sanitary and combined sewer manholes.

Separation of Water Mains and Storm Sewers

Horizontal Separation: Gravity Storm Sewers

Scenario	Requirements
Separation \geq 10 feet, edge to edge	No additional requirements
3 feet \leq separation < 10 feet, edge to edge	Option 1: construct water main of ductile iron pipe with gaskets impermeable to hydrocarbons, or Option 2: construct water main within watertight casing pipe with evenly spaced annular gap and watertight end seals, or Option 3: construct sewer of water main materials, or Option 4: reinforced concrete pipe storm sewers shall be constructed with gaskets manufactured in accordance with ASTM C443

*A minimum of 3 feet of horizontal separation shall be maintained.

Vertical Separation / Crossings: Gravity Storm Sewers

Scenario	Requirements
Separation \geq 18 inches	No additional requirements
6 inches \leq separation < 18 inches, water main located above sewer	Option 1: construct water main of ductile iron pipe with gaskets impermeable to hydrocarbons, or Option 2: construct water main within watertight casing pipe with evenly spaced annular gap and watertight end seals, or Option 3: construct sewer of water main materials, or Option 4: reinforced concrete pipe storm sewers shall be constructed with gaskets manufactured in accordance with ASTM C443
Separation < 6 inches, water main above sewer	Not allowed
Separation < 18 inches, water main below sewer	

RESOLUTION NO. 2026-28

ORDERING BIDS, APPROVING PLANS, SPECIFICATIONS, FORM OF CONTRACT AND NOTICE TO BIDDERS, FIXING AMOUNT OF BID SECURITY AND ORDERING CLERK TO PUBLISH NOTICE FOR A PUBLIC HEARING ON PLANS, SPECIFICATIONS, FORM OF CONTRACT AND ESTIMATE OF COSTS FOR THE CONSTRUCTION OF THE APRON RECONSTRUCTION IMPROVEMENTS PROJECT AT THE GRINNELL REGIONAL AIRPORT IN GRINNELL, IOWA

WHEREAS, the City Council previously directed Bolton & Menk, Inc. (the "Project Engineer") to prepare plans and specifications for the Apron Reconstruction Improvements Project at the Grinnell Regional Airport; and

WHEREAS the Project Engineer has prepared detailed plans and specification, form of contract and estimate of the cost for the construction of the Apron Reconstruction Improvements Project at the Grinnell Regional Airport in Grinnell, now on file in the office of the City Clerk of the City of Grinnell, Iowa; and

WHEREAS the cost of the said improvement is in excess of the amount required to hold a public bid and a public hearing on the plans, specifications, form of contract, and the estimated cost of said improvement is required by law and that notice thereof shall be given as required by law; and

WHEREAS it is intended that the cost of said improvement shall be paid from such funds as the City Council may legally use for such purposes and from grants in aid from the Iowa Department of Transportation and the Federal Aviation Administration; and

WHEREAS it is now necessary to advertise for bids and set a public hearing for approval of plans and specifications for the Apron Reconstruction Improvements Project at the Grinnell Regional Airport in Grinnell.

NOW, THEREFORE, BE IT RESOLVED BY THE City Council OF THE City of Grinnell, IOWA:

Section 1. The detailed plans and specifications as prepared by Bolton & Menk, Inc., and the form of contract and Notice to Bidders and Notice of Public Hearing, as approved, be and the same are hereby approved, subject to hearing thereon, and are hereby ordered placed on file in the office of the Clerk for public inspection.

Section 2. The Council does hereby order the construction of the Apron Reconstruction Improvements Project at the Grinnell Regional Airport, Grinnell, which public improvement is fully and particularly described in the plans and specifications, now on file in the office of the City Clerk of the City of Grinnell, Iowa.

Section 3. That the method of construction shall be by contract in accordance with the plans and specifications and general stipulations for said improvement approved by the City Council.

Section 4. The Contractor will be paid in monthly estimates for work completed as set out in the specifications. The project shall begin on or near the appropriate starting date as specified in the Project Manual and shall be completed by the completion date also indicated thereon.

Section 5. That the said improvements shall be paid for from such funds of the City of Grinnell, Iowa as may be legally used for such purposes and grants in aid from the Iowa Department of Transportation and Federal Aviation Administration.

Section 5. The City Council sets the amount of security to accompany each bid to be in the amount of 5% of the total bid, price pursuant to the provisions of Chapter 26 of the Code of Iowa, which bid security shall conform to the provisions of the Instructions to Bidders hereby approved.

Section 6. The City Clerk is hereby directed to publish notice of public hearing on plans, specifications, and form of contract and estimated cost in the manner provided by law for the public improvement outlined herein and that any person interested therein may appear and make objections thereto. The Council will meet in City Hall at 520 4th Avenue, Grinnell, Iowa, 50112, at 7:00 P.M. local time on the 20th day of April 2026, for the purpose of public hearing all of said objections so made and for taking final action upon the plans, specifications, and form of contract now on file.

Section 7. The City Clerk is further directed to advertise for bids in the manner provided by law for the construction of said improvements, setting forth in said notice such necessary pertinent information as will advise prospective bidders thereof together with the proposed manner of payment of the work to be constructed and that such bids be filed and received by the office of the City Clerk of City of Grinnell, Iowa, up to 2:00 P.M. local time on the 13th day of April 2026. The bids will be opened, read, and tabulated by the Project Engineer or their designate at that time and will be acted upon by the City Council at a meeting to be held in the City Hall at 520 4th Avenue, Grinnell, Iowa, 50112, at 7:00 P.M. local time on the 20th day of April 2026, or at such later time and place as may then be fixed for considering such bids as shall be filed in connection with the improvement herein ordered and in compliance with the notice of taking bids therein, hereby ordered to be published.

Passed this 16th day of March 2026.

CITY OF GRINNELL, IOWA

Sam Cox, Mayor

ATTEST:

Erienne Doll, Deputy City Clerk